

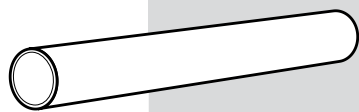

Rohre und Formteile aus PP / Pipes and fittings made of PP

Rohre / Pipe





	Seite
Prod.Gruppen 705	
SDR 7,4	96
SDR 11	97
SDR 17,6	98
SDR 26	99
SDR 33	100
SDR 41	101
Lüftungsreihe	102

Kurze Formteile / Fittings with short spigot

	MULTI-Bögen 90° / MULTI bend 90° Prod.Gruppe 068..... 103
---	---

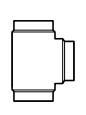
	Bögen 90° / Bend 90° Prod.Gruppe 001..... 104
--	---

	T-Stücke, T-Stücke mit red. Ab- gang / Tee Prod.Gruppe 006..... 105 Prod.Gruppe 016..... 107
---	---

	Vorschweißbunde / Stub flange Prod.Gruppe 012..... 108 V-Bunde für den Einbau von Ab- sperrklappen siehe im Kapitel „Flansche und Sonderteile“
---	---

	Losflansche / Backing ring Prod.Gruppe 014..... 110
---	---

	Reduktionen / Reducer Prod.Gruppe 941..... 111 Prod.Gruppe 007..... 114
---	---

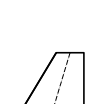
	Reduktionen exzentrisch / Reducer excentric Prod.Gruppe 005..... 115
---	--

	Seite
	Verschraubungen Typ 24 / Union type 24 Prod.Gruppe 024 116 Einschraubteil Typ24 116 Einlegteile Typ 24 116 Überwurfmutter Typ 24 117

	Adapter / Adaptor Prod.Gruppe 033 117 Prod.Gruppe 032 117
---	---

	Endkappe / End cap Prod.Gruppe 004 118
---	---

Lange Formteile / Fittings with long spigot

	MULTI-Bögen 90° / MULTI Bend 90° Prod.Gruppe 068 119
--	--

	Winkel 45° / Elbow 45° Prod.Gruppe 060 120
---	--

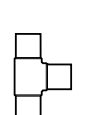
	T-Stücke, T-Stücke mit red. Abgang / Tee Prod.Gruppe 066 121 Prod.Gruppe 065 122
---	---

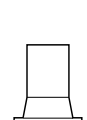
	Vorschweißbunde / Stub flange Prod.Gruppe 062 124 V-Bunde für den Einbau von Ab- sperrklappen siehe Kapitel „Flansche und Sonderteile“
---	---

	Losflansche / Backing ring Prod.Gruppe 014 125
---	--

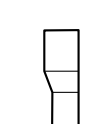
	Reduktionen exzentrisch / Reducer excentric Prod.Gruppe 069 126
---	---

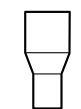
	Reduktionen / Reducer concentric Prod.Gruppe 067 127
---	--

	Endkappen / End cap Prod.Gruppe 064 128
---	--

Heizwendelformteile / Electrofusion fittings

	Muffen / E-coupler Prod.Gruppe 173 129
---	---

Formteile für Muffenschweißung / Fittings for socket welding

	Winkel 90° / Elbow 90° Prod.Gruppe 051 130
---	--

	Winkel 45° / Elbow 45° Prod.Gruppe 050 130
--	---

	T-Stücke, T-Stücke mit red. Ab- gang / Tee Prod.Gruppe 056 130 Prod.Gruppe 055 131
---	---

	Bundbuchsen / Flange adaptor Prod.Gruppe 052 131
---	--

	Muffen / Socket Prod.Gruppe 053 131
---	--

	Reduktionen / Reducer Prod.Gruppe 057 132
---	--

	Endkappen / End cap Prod.Gruppe 054 132
---	--

	Verschraubungen Typ 24 / Union type 24 Prod.Gruppe 024 133
---	--

	Adapter / Adaptor Prod.Gruppe 035 133 Prod.Gruppe 034 133
---	---

Rohre / Pipe

aus PP nach DIN 8077 / 78
in Standardlängen von 5 m

Artikelgruppe

PP-H

12 705...

SDR 7,4	d	s	d _i	kg/m
	12	2,0 ¹⁾	8,0	0,06
	20	2,8	14,4	0,15
	25	3,5	18,0	0,23
	32	4,4	23,3	0,37
	40	5,5	29,0	0,58
	50	6,9	36,2	0,90
	63	8,6	45,8	1,41
	75	10,3	54,4	2,01
	90	12,3	65,4	2,87
	110	15,1	79,8	4,30
	125	17,1	90,8	5,53
	140	19,2	101,6	6,95
	160	21,9	116,2	9,04

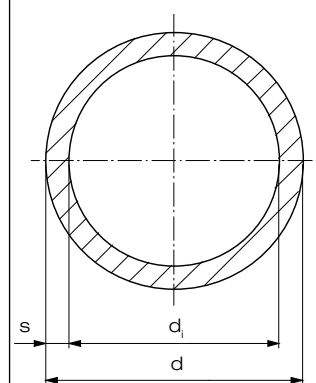

1) Aus schweißtechnischen Gründen sind die Wanddicken abweichend von der Norm ausgeführt.

Art.-Nr.	PP-H €/m
0012 07	1,60
0020 07	2,40
0025 07	3,55
0032 07	5,45
0040 07	7,35
0050 07	11,25
0063 07	17,50
0075 07	24,65
0090 07	35,30
0110 07	52,75
0125 07	67,80
0140 07	85,05
0160 07	110,80

Rabattgruppe
PP-H 62

Rohre / Pipe

aus PP nach DIN 8077 / 78
in Standardlängen von 5 m

DIBt
zugelassen

Artikelgruppe **PP-H** 12 705...

Artikelgruppe **PP-R** auf Anfrage

SDR 11	d	s	d _i	kg/m
	20	2,0 ¹⁾	16,4	0,11
	25	2,3	20,4	0,16
	32	2,9	26,2	0,26
	40	3,7	32,6	0,41
	50	4,6	40,8	0,64
	63	5,8	51,4	1,01
	75	6,8	61,4	1,41
	90	8,2	73,6	2,03
	110	10,0	90,0	3,01
	125	11,4	102,2	3,91
	140	12,7	114,6	4,87
	160	14,6	130,8	6,38
	180	16,4	147,2	8,07
	200	18,2	163,6	9,95
	225	20,5	184,0	11,26
	250	22,7	204,6	15,50
	280	25,4	229,2	19,40
	315	28,6	257,8	24,60
	355	32,2	290,6	31,20
	400 ²⁾	36,3	327,4	39,60
	450 ²⁾	40,9	368,2	50,10
	500 ²⁾	45,4	409,2	61,70

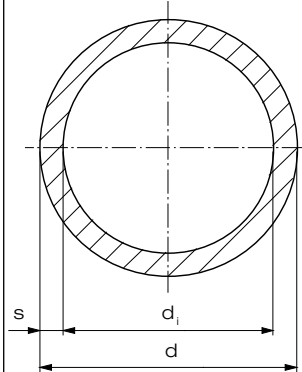

Sonderlängen auf Anfrage

- 1) Aus schweißtechnischen Gründen sind die Wanddicken abweichend von der Norm mit 2 mm ausgeführt.
2) nur in PP-R erhältlich

Art.-Nr.	PP-H €/m
0020 11	1,95
0025 11	2,60
0032 11	3,60
0040 11	4,70
0050 11	7,25
0063 11	11,30
0075 11	15,70
0090 11	22,35
0110 11	33,25
0125 11	42,90
0140 11	53,70
0160 11	70,30
0180 11	88,70
0200 11	109,20
0225 11	138,70
0250 11	170,45
0280 11	213,25
0315 11	270,45
0355 11	410,00
0400 11	520,65
0450 11	674,80
0500 11	831,00

Rabattgruppe
PP-H 108

Rohre / Pipe

aus PP nach DIN 8077 / 78
in Standardlängen von 5 m

DIBt
zugelassen

Artikelgruppe **PP-H** 12 705...

Artikelgruppe **PP-R** auf Anfrage

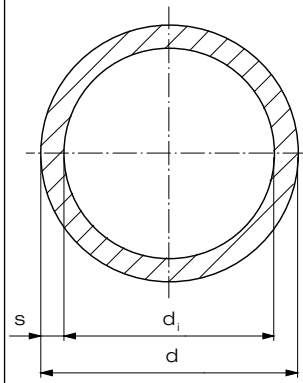
SDR 17,6	d	s	d _i	kg/m
	32	2,0 ¹⁾	28,0	0,17
	40	2,3	35,4	0,27
	50	2,9	44,2	0,42
	63	3,6	55,8	0,66
	75	4,3	66,4	0,94
	90	5,1	79,8	1,33
	110	6,3	97,4	1,99
	125	7,1	110,8	2,55
	140	8,0	124,0	3,20
	160	9,1	141,8	4,17
	180	10,2	159,6	5,25
	200	11,4	177,2	6,50
	225	12,8	199,4	8,19
	250	14,2	221,6	10,10
	280	15,9	248,2	12,60
	315	17,9	279,2	16,00
	355	20,1	314,8	20,30
	400	22,7	354,6	25,70
	450	25,5	399,0	32,50
	500	28,3	443,4	40,10
	560	31,7	496,6	50,30
	630	35,7	558,6	63,70
	710 ²⁾	40,2	629,6	80,80
	800 ²⁾	45,3	709,4	103,00
	900 ²⁾	51,0	798,0	130,00
	1000 ²⁾	56,7	886,6	167,56

Sonderlängen auf Anfrage

1) Aus schweißtechnischen Gründen sind die Wanddicken abweichend von der Norm ausgeführt.

2) nur in PP-R erhältlich

Art.-Nr.	PP-H €/m
0032 17	2,95
0040 17	4,15
0050 17	4,85
0063 17	7,50
0075 17	10,40
0090 17	14,75
0110 17	22,10
0125 17	28,05
0140 17	35,45
0160 17	45,85
0180 17	57,60
0200 17	71,25
0225 17	90,20
0250 17	111,20
0280 17	138,70
0315 17	176,00
0355 17	266,40
0400 17	330,80
0450 17	416,00
0500 17	513,25
0560 17	643,60
0630 17	814,90
0710 17	1.032,50
0800 17	1.312,60
0900 17	a.A.
1000 17	a.A.

Rabattgruppe
PP-H 108

Rohre / Pipe

aus PP nach DIN 8077 / 78
in Standardlängen von 5 m

Artikelgruppe

PP-H

12 705...

PP

SDR 26	d	s	d _i	kg/m
	40	2,0 ¹⁾	36,0	0,22
	50	2,0	46,0	0,30
	63	2,5	58,0	0,47
	75	2,9	69,2	0,65
	90	3,5	83,0	0,94
	110	4,2	101,6	1,37
	125	4,8	115,4	1,76
	140	5,4	129,2	2,23
	160	6,2	147,6	2,92
	180	6,9	166,2	3,63
	200	7,7	184,6	4,50
	225	8,6	207,8	5,65
	250	9,6	230,8	6,99
	280	10,7	258,6	8,72
	315	12,1	290,8	11,10
	355	13,6	327,8	14,00
	400	15,3	369,4	17,80
	450	17,2	415,6	22,50
	500	19,1	461,8	27,70
	560	21,4	517,2	34,70
	630	24,1	581,8	44,00
	710	27,2	655,6	55,90
	800	30,6	738,8	70,80
	900	34,4	831,2	89,50
	1000	38,2	923,6	110,00
	1200	45,9	1108,2	159,00
	1400	53,5	1293,0	216,00

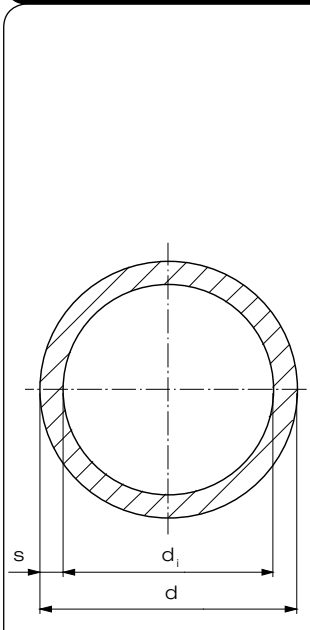

Sonderlängen auf Anfrage

1) Aus schweißtechnischen Gründen sind die Wanddicken abweichend von der Norm ausgeführt.

Art.-Nr.	PP-H €/m.
0040 26	2,90
0050 26	3,85
0063 26	6,00
0075 26	8,15
0090 26	11,70
0110 26	16,90
0125 26	21,70
0140 26	27,35
0160 26	35,60
0180 26	44,65
0200 26	55,20
0225 26	69,25
0250 26	85,75
0280 26	106,90
0315 26	136,15
0355 26	171,50
0400 26	216,80
0450 26	294,25
0500 26	362,60
0560 26	466,15
0630 26	665,25
0710 26	845,50
0800 26	1.072,70
0900 26	1.356,10
1000 26	1.668,50
1200 26	a.A
1400 26	a.A

Rabattgruppe
PP-H 62

P.VDF / ECTFE

Sonderwerkstoffe

PURAD

Flansche und Sonderstücke

Armaturen

Doppelrohr

Halbzeuge / Wickelrohr

PKS, Schächte Sonderbauteile

Betonschutzplatten

Geothermie

Schweißtechnik

Rohre / Pipe

aus PP nach DIN 8077 / 78
in Standardlängen von 5 m

Artikelgruppe

PP-H

12 705...

SDR 33				
	d	s	d _i	kg/m
	50	2,0 ¹⁾	46,0	0,27
	63	2,0	59,0	0,38
	75	2,3	70,4	0,53
	90	2,8	84,4	0,76
	110	3,4	103,0	1,12
	125	3,9	117,2	1,45
	140	4,3	131,4	1,80
	160	4,9	150,2	2,32
	180	5,5	169,0	2,94
	200	6,2	187,6	3,68
	225	6,9	211,2	4,57
	250	7,7	234,6	5,67
	280	8,6	262,8	7,09
	315	9,7	295,6	8,97
	355	10,9	332,8	11,30
	400	12,3	375,4	14,40
	450	13,8	422,4	18,20
	500	15,3	469,4	22,40
	560	17,2	525,6	28,20
	630	19,3	591,4	35,60
	710	21,8	666,4	45,20
	800	24,5	751,0	57,20
	900	27,6	844,8	72,50
	1000	30,6	938,8	89,20
	1200	36,7	1126,6	128,00

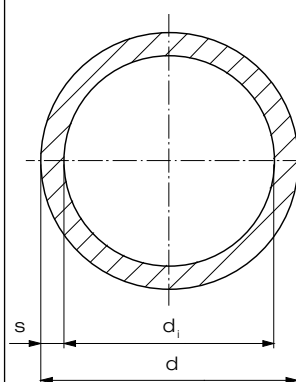

Sonderlängen auf Anfrage

1) Aus schweißtechnischen Gründen sind die Wanddicken abweichend von der Norm ausgeführt.

PP Art.-Nr.	PP-H €/m
0050 33	3,85
0063 33	4,85
0075 33	6,55
0090 33	9,45
0110 33	13,85
0125 33	17,95
0140 33	22,00
0160 33	28,70
0180 33	36,20
0200 33	44,85
0225 33	56,10
0250 33	69,60
0280 33	87,00
0315 33	109,95
0355 33	138,40
0400 33	176,40
0450 33	239,15
0500 33	300,45
0560 33	378,60
0630 33	526,05
0710 33	669,70
0800 33	847,45
0900 33	1.099,75
1000 33	1.353,10
1200 33	2.020,55

Rabattgruppe
PP-H 62

Rohre / Pipe

aus PP nach DIN 8077 / 78
in Standardlängen von 5 m

Artikelgruppe

PP-H

12 705...

PP

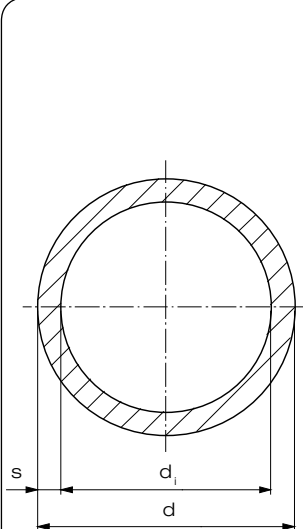
SDR 41				
	d	s	d _i	kg/m
	63	2,0 ¹⁾	59,4	0,35
	75	2,0 ¹⁾	71,2	0,44
	90	2,2	85,6	0,62
	110	2,7	104,6	0,90
	125	3,1	118,8	1,18
	140	3,5	133,0	1,48
	160	4,0	152,2	1,91
	180	4,4	171,2	2,38
	200	4,9	190,2	2,92
	225	5,5	214,0	3,70
	250	6,2	237,6	4,63
	280	6,9	266,2	5,73
	315	7,7	299,6	7,20
	355	8,7	337,6	9,14
	400	9,8	380,4	11,60
	450	11,0	428,0	14,70
	500	12,3	475,4	18,20
	560	13,7	532,6	22,60
	630	15,4	599,2	28,60
	710	17,4	675,2	36,40
	800	19,6	760,8	46,10
	900	22,0	856,0	58,30
	1000	24,5	951,0	72,00
	1200	29,4	1141,2	104,00
	1400	34,3	1331,4	141,00

Sonderlängen auf Anfrage

1) Aus schweißtechnischen Gründen sind die Wanddicken abweichend von der Norm ausgeführt.

PP Art.-Nr.	PP-H €/m
0063 41	4,75
0075 41	5,95
0090 41	8,00
0110 41	11,80
0125 41	15,25
0140 41	19,25
0160 41	24,75
0180 41	30,60
0200 41	37,70
0225 41	47,85
0250 41	59,25
0280 41	74,05
0315 41	92,70
0355 41	117,85
0400 41	149,45
0450 41	201,75
0500 41	251,35
0560 41	312,15
0630 41	422,35
0710 41	537,85
0800 41	682,95
0900 41	914,85
1000 41	1.133,55
1200 41	1.703,50
1400 41	2.331,75

Rabattgruppe
PP-H 62

P.VDF / ECTFE

Sonderwerkstoffe

PURAD

Flansche und Sonderbauteile

Armaturen

Doppelrohr

Halbzeuge / Wickelrohr

PKS, Schächte Sonderbauteile

Betonschutzplatten

Geothermie

Schweißtechnik

Rohre / Pipe

aus PP
in Längen von 5 m

Artikelgruppe

PP-H

12 705...

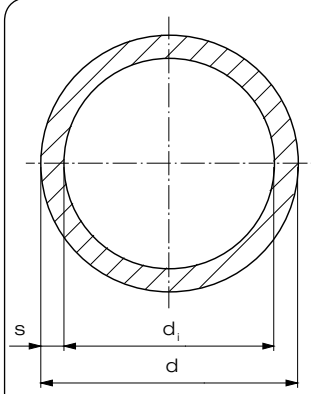
Lüftungsreihe	d	s	d _i	kg/m
	200	3,0	194	1,83
	250	3,5	243	2,66
	315	5,0	305	4,74
	355	6,0	343	6,39
	400	6,0	388	7,20
	450	6,0	438	8,10
	500	8,0	484	11,90
	560	8,0	540	13,41
	630	10,0	610	18,80
	710	12,0	686	25,30
	800	12,0	776	28,60
	900	15,0	870	40,10
	1000	15,0	970	44,60
	1200	18,0	1164	64,10
	1400	20,0	1360	83,20

Sonderlängen auf Anfrage

€/m	PP-H €/m
0200 00	26,00
0250 00	37,70
0315 00	67,20
0355 00	75,70
0400 00	102,00
0450 00	122,05
0500 00	179,15
0560 00	249,65
0630 00	282,70
0710 00	380,50
0800 00	430,00
0900 00	644,20
1000 00	716,40
1200 00	1.091,15
1400 00	1.416,25

Rabattgruppe
PP-H 71