

# Sonderwerkstoffe / Special materials







PPs

PPs-el

PE 100-el



	Seite
	Rohre / Pipe Prod.Gruppe 705 .....204
	Bögen 90° / Bend 90° Prod.Gruppe 001 .....205
	T-Stücke / Tee Prod.Gruppe 006 .....206
	Vorschweißbunde / Stub flange Prod.Gruppe 012 .....207
	Losflansche / Backing ring Prod.Gruppe 014 .....208
	Reduktionen / Reducer Prod.Gruppe 007 .....208





	Seite
	Rohre / Pipe Prod.Gruppen 705 ..... 210
	Bögen 90° / Bend 90° Prod.Gruppe 001 ..... 211
	T-Stücke / Tee Prod.Gruppe 006 ..... 212
	Vorschweißbunde / Stub flange Prod.Gruppe 012 ..... 214
	Losflansche / Backing ring Prod.Gruppe 014 ..... 215
	Reduktionen / Reducer Prod.Gruppe 007 ..... 216

	Seite
	Rohre / Pipe Prod.Gruppen 705 .....217
	MULTI-Bögen 90° / MULTI bend 90° Prod.Gruppe 068 ..... 218
	Bögen 90° / Bend 90° Prod.Gruppe 001 ..... 219
	T-Stücke / Tee Prod.Gruppe 006 .....220
	Vorschweißbunde / Stub flange Prod.Gruppe 012 ..... 221
	Losflansche / Backing ring Prod.Gruppe 014 .....223
	Reduktionen / Reducer Prod.Gruppe 007 .....224

**NEU** PA

**NEU** PA

	Seite
	Rohre / Pipe Prod.Gruppe 709 SureAMID .....225
	Muffen / E-coupler Prod.Gruppe 173 <b>NEU</b> .....225
	Winkel 45° / Elbow 45° Prod.Gruppe 060 <b>NEU</b> .....226

	Seite
	Vorschweißbunde / Stub flange Prod.Gruppe 062 <b>NEU</b> .....226
	Losflansche / Backing ring Prod.Gruppe 014 .....227
	Reduktionen / Reducer Prod.Gruppe 067 <b>NEU</b> .....227
	Endkappen / End cap Prod.Gruppe 064 <b>NEU</b> .....228

PE  
PP  
PVD/ECTFE  
PPA/FEP/PURAD  
PPs/PPs-el  
PE-el/PA  
Luftung  
Flansche und  
Sonderteile  
Armaturen  
Doppelrohr  
Halbzeugs/  
Betonstützplatten  
PKS®-Bauteile;  
Sure Inspect RC  
Geobaustoffe  
Kabelschutz/  
Ecomiles  
Geothermie  
Schweißtechnik

## Rohre / Pipe

aus PPs

Standardlänge 5 m

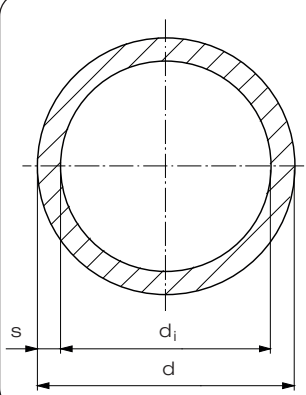
SDR 11	d	s	d <sub>i</sub>	kg/m
	20	2,0	16,2	0,12
	25	2,3	20,4	0,17
	32	3,0	26,2	0,27
	40	3,7	32,6	0,42
	50	4,6	40,8	0,65
	63	5,8	51,4	1,03
	75	6,8	61,4	1,44
	110 <sup>1)</sup>	10,0	90,0	3,09
	140 <sup>1)</sup>	12,7	114,6	4,99
	160 <sup>1)</sup>	14,6	130,8	6,55

1) Auslaufartikel

Artikelgruppe

PPs

17 705...

Art.-Nr.

€/m

0020 11	3,95
0025 11	5,65
0032 11	9,05
0040 11	11,90
0050 11	18,35
0063 11	28,85
0075 11	40,40
0110 11	86,95
0140 11	139,90
0160 11	227,80

Rabattgruppe  
68

## Bögen 90° / Bend 90°

formgespritzt, aus PPs,  
r = d

SDR 11					
	d	s	z	l <sub>e</sub>	VE <sup>1)</sup>
	20	1,9	32	10	240
	25	2,3	38	8	160
	32	2,9	43	11	120
	40	3,7	46	6	80
	50	4,6	58	8	100
	63	5,8	70	7	50
	75	6,8	85	10	30
	90	8,2	100	10	16
	110	10,0	124	14	20
	140	12,7	150	10	10
	160	14,6	180	25	6

1) VE = Verpackungseinheit im Karton

Artikelgruppe PPs 17 001...

Art.-Nr.	€/Stück
0020 11	7,10
0025 11	4,15
0032 11	7,65
0040 11	9,85
0050 11	12,40
0063 11	17,80
0075 11	24,40
0090 11	35,40
0110 11	67,50
0140 11	127,00
0160 11	185,70

Rabattgruppe  
53

## Bögen 90° / Bend 90°

formgespritzt, aus PPs,  
r = d

SDR 33					
	d	s	z	l <sub>e</sub>	VE <sup>1)</sup>
	110	3,4	120	10	20
	160	4,9	177	22	6
	180	5,5	200	20	5
	200	6,2	220	20	6
	225	6,9	245	20	5
	250	7,7	290	25	3
	280	8,6	290	25	3
	315	9,7	340	40	1
	355	10,9	340	40	1
	400	12,3	345	45	1

1) VE = Verpackungseinheit im Karton

Artikelgruppe PPs 17 001...

Art.-Nr.	€/Stück
0110 33	45,10
0160 33	85,55
0180 33	104,25
0200 33	129,30
0225 33	159,15
0250 33	233,90
0280 33	294,70
0315 33	422,20
0355 33	916,70
0400 33	1.285,50

Rabattgruppe  
53

## T-Stücke / Tee

verstärkt, formgespritzt, aus PPs,

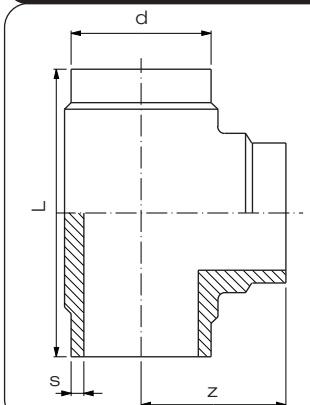
SDR 11	d	s	L	z	VE <sup>1)</sup>
	20	2,5	70	35	160
	25	2,7	78	40	200
	32	2,9	88	46	120
	40	3,7	90	50	50
	50	4,6	100	52	50
	63	5,8	125	65	30
	75	6,8	147	75	20
	90	8,2	207	106	8
	110	10,0	240	120	13
	140	12,7	293	145	6
	160	14,6	315	160	4

1)- VE = Verpackungseinheit im Karton

Artikelgruppe

PPs

17 006...

Art.-Nr.	€/Stück
0020 11	5,70
0025 11	5,70
0032 11	7,15
0040 11	11,30
0050 11	15,15
0063 11	23,55
0075 11	47,50
0090 11	70,90
0110 11	104,15
0140 11	189,15
0160 11	305,45

Rabattgruppe  
53

## T-Stücke / Tee

verstärkt, formgespritzt, aus PPs,

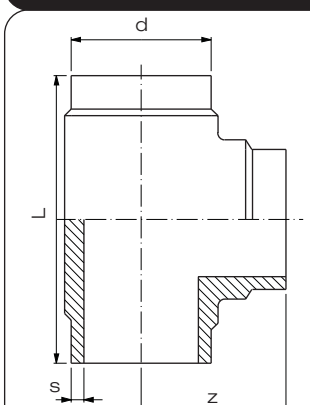
SDR 33	d	s	L	z	VE <sup>1)</sup>
	110	3,4	223	109	13
	160	4,9	346	173	4
	180	5,5	372	186	4
	200	6,2	405	202	3
	225	6,9	440	220	3
	250	7,7	475	237	3
	280	8,6	540	270	1
	315	9,7	550	275	1

1) VE = Verpackungseinheit im Karton

Artikelgruppe

PPs

17 006...

Art.-Nr.	€/Stück
0110 33	58,95
0160 33	140,45
0180 33	194,70
0200 33	263,25
0225 33	367,95
0250 33	568,90
0280 33	724,40
0315 33	916,35

Rabattgruppe  
53

## Vorschweißbunde / Stub flange

formgespritzt, aus PPs,

SDR 11	d	s	z	h <sub>1</sub>	d <sub>3</sub>	d <sub>4</sub>	VE <sup>1)</sup>
	20	1,9	52	7	27	45	160
	25	2,3	50	9	33	58	200
	32	2,9	50	10	40	68	40
	40	3,7	50	11	50	78	50
	50	4,6	50	12	61	88	80
	63	5,8	50	14	75	102	60
	75	6,8	50	16	89	122	40
	90	8,2	80	17	105	138	20
	110	10,0	80	18	125	158	40
	140	12,7	92	25	155	188	28
	160	14,6	92	25	175	212	20

1) VE = Verpackungseinheit im Karton

Artikelgruppe **PPs** 17 012...

Art.-Nr.	€/Stück
0020 11	6,45
0025 11	6,45
0032 11	7,60
0040 11	9,10
0050 11	11,05
0063 11	13,90
0075 11	16,25
0090 11	26,05
0110 11	34,85
0140 11	56,30
0160 11	73,55

Rabattgruppe  
53

## Vorschweißbunde / Stub flange

formgespritzt, aus PPs,

SDR 33	d	s	z	h <sub>1</sub>	d <sub>3</sub>	d <sub>4</sub>	VE <sup>1)</sup>
	110	3,4	80	18	125	158	40
	160	4,9	80	18	175	212	20
	180	5,5	92	18	183	212	20
	200	6,2	113	18	232	268	9
	225	6,9	113	18	235	268	9
	250	7,7	132	20	285	320	5
	280	8,6	128	20	291	320	5
	315	9,7	136	20	335	370	4
	355	10,9	120	23	373	430	10
	400	12,3	120	26	427	482	8
	500	15,3	120	33	530	585	6

1) VE = Verpackungseinheit im Karton

Artikelgruppe **PPs** 17 012...

Art.-Nr.	€/Stück
0110 33	27,30
0160 33	48,05
0180 33	70,25
0200 33	90,85
0225 33	94,60
0250 33	140,65
0280 33	143,85
0315 33	172,35
0355 33	339,00
0400 33	613,90
0500 33	873,05

Rabattgruppe  
53



## Reduktionen / Reducer concentric

zentrisch, aus PPs,  
formgespritzt, stufenweise abgesetzt

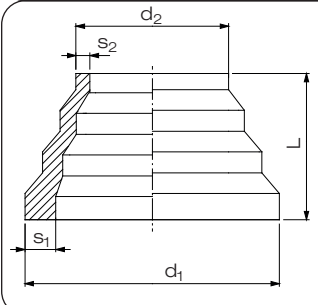
SDR 33	$d_1$	$d_2$	$s_1$	$s_2$	L	VE <sup>1)</sup>
	110	63	3,4	2,0	97	50
	125	75	3,9	2,3	72	30
	160	110	4,9	3,4	83	18
	225	160	6,9	4,9	90	12
	315	225	9,7	6,9	130	10

1) VE = Verpackungseinheit im Karton

Artikelgruppe **PPs** 17 007...

Art.-Nr.	€/Stück
1163 33	25,65
1275 33	29,30
1611 33	92,65
2216 33	234,95
3122 33	270,35

Rabattgruppe  
53

## Rohre / Pipe

aus PPs-el schwarz, MOP 6 bar  
Standardlänge 5 m

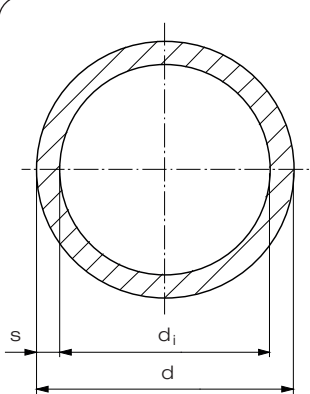
SDR 11	d	s	d <sub>i</sub>	kg/m
	32	3,0	26,2	0,32
	50	4,6	40,8	0,79
	63	5,8	51,4	1,25
	75	6,8	61,4	1,74
	90	8,2	73,6	2,51
	110	10,0	90,0	3,31

## Rohre / Pipe

aus PPs-el schwarz, MOP 3,5 bar  
Standardlänge 5 m

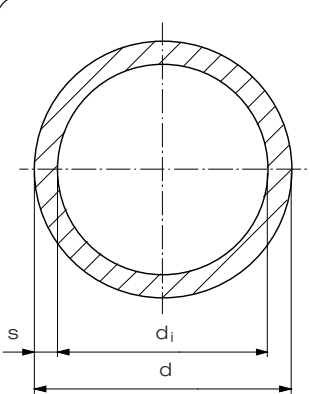
SDR 17,6	d	s	d <sub>i</sub>	kg/m
	110	6,3	97,4	2,46
	160	9,1	141,8	5,15
	200	11,4	177,2	8,05

## Rohre / Pipe

aus PPs-el schwarz, MOP 1,5 bar  
Standardlänge 5 m

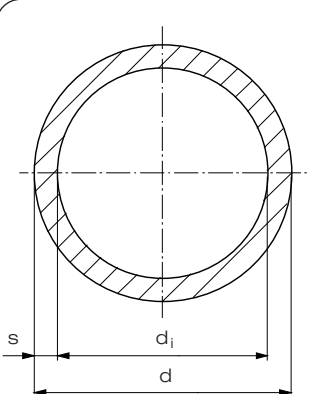
SDR 33	d	s	d <sub>i</sub>	kg/m
	90	2,8	84,4	0,93
	110	3,4	103,0	1,40
	160	4,9	150,2	2,90
	200	6,2	187,6	4,50
	225	6,9	211,2	5,86
	315	9,7	295,6	11,14

Artikelgruppe PPs-el 19 705...

Art.-Nr.	€/m
0032 11	20,05
0050 11	49,05
0063 11	77,25
0075 11	107,70
0090 11	155,90
0110 11	230,95

Rabattgruppe  
72

Artikelgruppe PPs-el 19 705...

Art.-Nr.	€/m
0110 17	152,80
0160 17	319,65
0200 17	498,40

Rabattgruppe  
72

Artikelgruppe PPs-el 19 705...

Art.-Nr.	€/m
0090 33	58,20
0110 33	86,30
0160 33	178,15
0200 33	281,90
0225 33	350,65
0315 33	687,95

Rabattgruppe  
72

## Bögen 90° / Bend 90°

formgespritzt, aus PPs-el, MOP 6 bar  
r = d

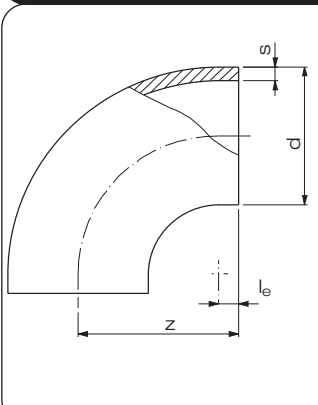
SDR 11	d	s	z	l <sub>e</sub>	VE <sup>1)</sup>
	32	2,9	43	11	120
	50	4,6	58	8	100
	63	5,8	70	7	50
	75	6,6	85	10	30
	90	8,2	100	10	16
	110	10,0	124	14	20

1) VE = Verpackungseinheit im Karton

Artikelgruppe PPs-el 19 001...

Art.-Nr.	€/Stück
0032 11	10,20
0050 11	16,50
0063 11	23,60
0075 11	32,65
0090 11	47,15
0110 11	90,65

Rabattgruppe 52

## Bögen 90° / Bend 90°

formgespritzt, aus PPs-el, MOP 3,5 bar  
r = d

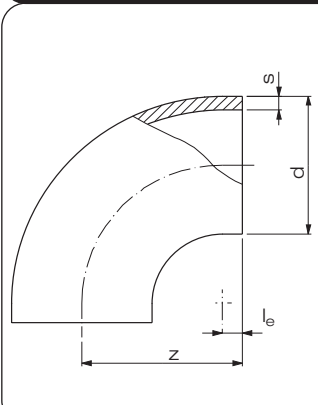
SDR 17	d	s	z	l <sub>e</sub>	VE <sup>1)</sup>
	110	6,6	123	13	20
	160	9,5	180	25	6
	200	11,9	220	20	6

1) VE = Verpackungseinheit im Karton

Artikelgruppe PPs-el 19 001...

Art.-Nr.	€/Stück
0110 17	87,60
0160 17	178,25
0200 17	270,60

Rabattgruppe 52

## Bögen 90° / Bend 90°

formgespritzt, aus PPs-el, MOP 1,5 bar  
r = d

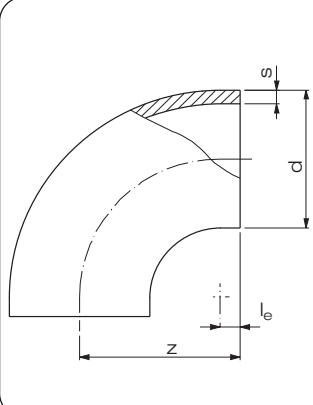
SDR 33	d	s	z	l <sub>e</sub>	VE <sup>1)</sup>
	110	3,4	120	10	20
	160	4,9	180	22	6
	200	6,2	220	20	6
	225	6,9	250	25	5
	250	7,7	290	25	3
	315	9,7	340	40	1
	SDR 33				

1) VE = Verpackungseinheit im Karton

Artikelgruppe PPs-el 19 001...

Art.-Nr.	€/Stück
0110 33	60,05
0160 33	114,00
0200 33	172,40
0225 33	212,05
0250 33	358,60
0315 33	627,05

Rabattgruppe  
52

## T-Stücke / Tee

verstärkt,  
formgespritzt, aus PPs-el, MOP 6 bar

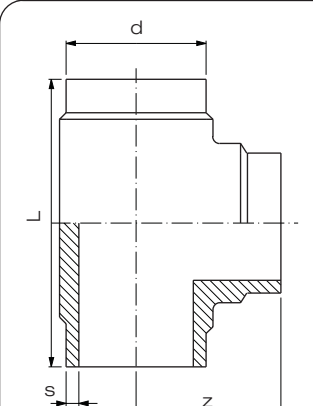
SDR 11	d	s	L	z	VE <sup>1)</sup>
	32	2,9	90	4	120
	50	4,6	120	60	50
	63	5,8	144	72	30
	75	6,8	152	75	20
	90	8,2	213	105	8
	110	10,0	253	122	12
	SDR 11				

1) VE = Verpackungseinheit im Karton

Artikelgruppe PPs-el 19 006...

Art.-Nr.	€/Stück
0032 11	9,45
0050 11	20,20
0063 11	31,40
0075 11	63,40
0090 11	94,50
0110 11	139,90

Rabattgruppe  
52

## T-Stücke / Tee

verstärkt,  
formgespritzt, aus PPs-el, MOP 3,5 bar

SDR 17		d	s	L	z	VE <sup>1)</sup>
	110	6,6	251	121,0	13	
	160	9,5	346	173,0	4	
	200	11,9	405	202,5	4	

1) VE = Verpackungseinheit im Karton

Artikelgruppe PPs-el 19 006...

Art.-Nr.	€/Stück
0110 17	118,05
0160 17	362,90
0200 17	608,70

Rabattgruppe  
52

## T-Stücke / Tee

verstärkt,  
formgespritzt, aus PPs-el, MOP 1,5 bar

SDR 33		d	s	L	z	VE <sup>1)</sup>
	110	3,4	223	109,0	13	
	160	4,9	346	173,0	4	
	200	6,2	405	202,5	6	
	225	6,9	440	220,0	3	
	250	7,7	475	237,0	3	
	315	9,7	550	275,0	1	

1) VE = Verpackungseinheit im Karton

Artikelgruppe PPs-el 19 006...

Art.-Nr.	€/Stück
0110 33	78,55
0160 33	199,35
0200 33	355,60
0225 33	490,25
0250 33	758,50
0315 33	1.218,15

Rabattgruppe  
52

## Vorschweißbunde / Stub flange

formgespritzt, aus PPs-el, MOP 6 bar

Artikelgruppe PPs-el 19 012...

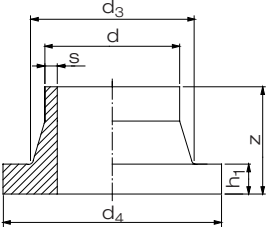
SDR 11	d	s	z	h <sub>1</sub>	d <sub>3</sub>	d <sub>4</sub>	VE <sup>1)</sup>
	32	2,9	50	10	40	68	80
	50	4,6	50	12	61	88	80
	63	5,8	50	14	75	102	60
	75	6,8	50	16	89	122	40
	90	8,2	80	17	105	138	20
	110	10,0	80	18	125	158	40

1) VE = Verpackungseinheit im Karton

Art.-Nr.	€/Stück
0032 11	10,05
0050 11	14,70
0063 11	18,40
0075 11	21,80
0090 11	37,35
0110 11	49,20

Rabattgruppe  
52

## Vorschweißbunde / Stub flange

formgespritzt, aus PPs-el, MOP 3,5 bar

Artikelgruppe PPs-el 19 012...

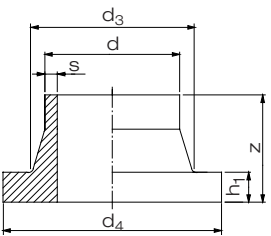
SDR 17	d	s	z	h <sub>1</sub>	d <sub>3</sub>	d <sub>4</sub>	VE <sup>1)</sup>
	110	6,6	80	18	125	158	40
	160	9,5	92	18	175	212	20
	200	11,9	110	24	232	268	8

1) VE = Verpackungseinheit im Karton

Art.-Nr.	€/Stück
0110 17	40,65
0160 17	77,15
0200 17	162,85

Rabattgruppe  
52

## Vorschweißbunde / Stub flange

formgespritzt, aus PPs-el, MOP 1,5 bar

Artikelgruppe **PPs-el** 19 012...

SDR 33		d	s	z	h <sub>1</sub>	d <sub>3</sub>	d <sub>4</sub>	VE <sup>1)</sup>
	110	3,4	80	18	125	158	40	
	160	4,9	80	18	175	212	18	
	200	6,2	113	18	232	268	8	
	225	6,9	113	18	235	268	8	
	250	7,7	132	20	285	320	5	
	315	9,7	136	20	335	370	4	

1) VE = Verpackungseinheit im Karton

Art.-Nr.	€/Stück
0110 33	36,35
0160 33	64,05
0200 33	112,55
0225 33	126,20
0250 33	196,05
0315 33	229,70

Rabattgruppe  
52

## Losflansche Typ „VB“ / Backing ring type „VB“ nach DIN EN ISO 15494 für Vorschweißbunde

PPs-el in Schwarz, glasfaserverstärkt,  
mit Stahleinlage, Lochbild nach DIN EN 1092-1, bis d 180 = PN 10/ PN 16;  
ab d 200 = PN 10

Artikelgruppe **PPs-el** 19 014...

PN 10 / PN 16	Lochbild							VE <sup>1)</sup>
	d	DN	D	d <sub>6</sub>	k	d <sub>2</sub>	b	
bis d 315 bis PN 16 einsetzbar  	32	25	115	42	85	4 x 14	16	30
	40	32	140	51	100	4 x 18	18	30
	50	40	150	62	110	4 x 18	18	16
	63	50	165	78	125	4 x 18	18	16
	75	65	187	92	145	4 x 18	18	15
	90	80	202	108	160	8 x 18	20	10
	110/125	100	220	133	180	8 x 18	20	11
	160/180	150	286	190	240	8 x 22	23	10
	200	200	340	235	295	8 x 22	24	5
	225	200	340	238	295	8 x 22	24	5
	250	250	409	288	350	12 x 22	30	lose
	315	300	463	338	400	12 x 22	34	lose

1) VE = Verpackungseinheit im Karton

Art.-Nr.	€/Stück
0032 11	31,30
0040 11	39,50
0050 11	46,35
0063 11	53,40
0075 11	59,25
0090 11	70,50
0110 11	112,45
0160 11	163,60
0200 11	210,35
0225 11	210,35
0250 11	335,55
0315 11	421,80

Rabattgruppe  
52



## Rohre / Pipe

aus PE 100-el schwarz  
Standardlänge 5 m

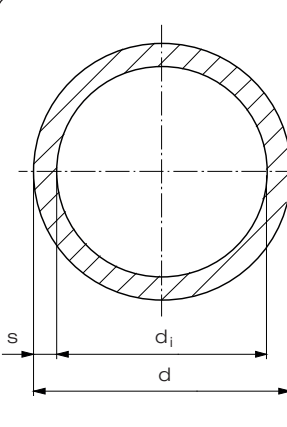
SDR 11				
	d	s	d <sub>i</sub>	kg/m
	32	3,0	26,2	0,3
	40	3,7	32,6	0,5
	50	4,6	40,8	0,7
	63	5,8	51,4	1,2
	75	6,8	61,4	1,6
	90	8,2	73,6	2,4
	110	10,0	90,0	3,5
	125	11,4	102,2	4,5
	160	14,6	130,8	7,4
	180	16,4	147,2	9,3
	200	18,2	163,6	11,5
	225	20,5	184,0	14,5
	250	22,7	204,6	17,9
	315	28,6	257,8	28,3

Artikelgruppe **PE 100-el** 28 705...

Art.-Nr.	€/m
0032 11	11,20
0040 11	17,70
0050 11	27,10
0063 11	43,15
0075 11	60,00
0090 11	86,20
0110 11	128,65
0125 11	165,85
0160 11	272,50
0180 11	342,95
0200 11	423,40
0225 11	536,90
0250 11	658,45
0315 11	1.046,50

Rabattgruppe  
110

## Rohre / Pipe

aus PE 100-el schwarz  
Standardlänge 5 m

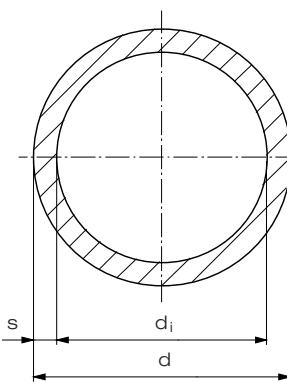
SDR 17,6				
	d	s	d <sub>i</sub>	kg/m
	90	5,1	79,8	1,5
	110	6,3	97,4	2,3
	125	7,1	110,8	2,9
	160	9,1	141,8	4,8
	180	10,2	159,6	6,1
	200	11,4	177,2	7,5
	225	12,8	199,4	9,5
	250	14,2	221,6	11,7
	315	17,9	279,2	18,5

Artikelgruppe **PE 100-el** 28 705...

Art.-Nr.	€/m
0090 17	59,30
0110 17	87,60
0125 17	112,25
0160 17	183,35
0180 17	232,25
0200 17	286,65
0225 17	364,75
0250 17	445,80
0315 17	707,95

Rabattgruppe  
110

## Rohre / Pipe

aus PE 100-el schwarz  
Standardlänge 5 m

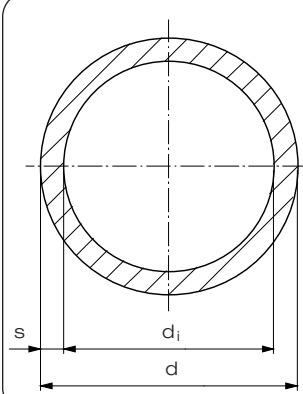
SDR 33				
	d	s	d <sub>i</sub>	kg/m
	110	3,4	103,0	1,3
	125	3,9	117,2	1,7
	160	4,9	150,2	2,7
	180	5,5	169,0	3,4
	200	6,2	187,6	4,2
	225	6,9	211,2	5,3
	250	7,7	234,6	6,5
	315	9,7	295,6	10,4
	400	12,3	375,4	16,7

Artikelgruppe PE 100-el 28 705...

Art.-Nr.	€/m
0110 33	47,40
0125 33	61,95
0160 33	99,15
0180 33	125,05
0200 33	155,60
0225 33	195,15
0250 33	241,85
0315 33	382,50
0400 33	611,60

Rabattgruppe  
110

## MULTI-Bögen 90° / MULTI bend 90°

**NEU**

formgespritzt, aus PE 100-el,  
mit langen Schweißenden,  $r \approx d$

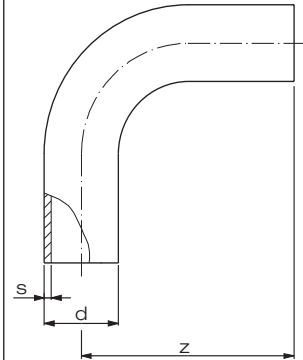
SDR 11				
	d	s	z	VE <sup>1)</sup>
	32	2,9	79,0	50
	40	3,7	92,5	30
	50	4,6	108,5	40
	63	5,8	129,5	20
	75	6,8	150,0	14
	90	8,2	168,0	8
	110	10,0	192,0	14
	125	11,4	218,0	15
	160	14,6	260,0	4

Artikelgruppe PE 100-el 28 068...

Art.-Nr.	€/Stück
0032 11	9,25
0040 11	12,75
0050 11	16,30
0063 11	24,45
0075 11	35,00
0090 11	51,90
0110 11	94,50
0125 11	139,85
0160 11	280,85

Rabattgruppe  
54

1) VE = Verpackungseinheit

## MULTI-Bögen 90° / MULTI bend 90°

formgespritzt, aus PE 100-el,  
mit langen Schweißenden,  $r \approx d$

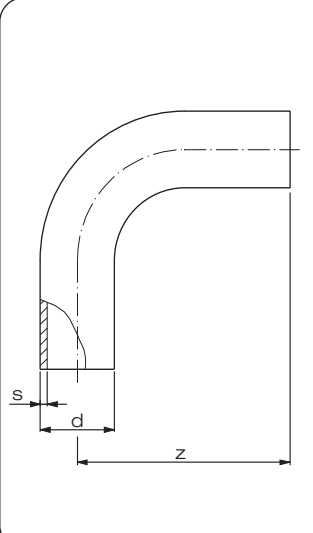
SDR 17				
	d	s	z	VE <sup>1)</sup>
	110	6,6	192,0	14
	125	7,4	218,0	8
	160	9,5	261,5	4

1) VE = Verpackungseinheit

Artikelgruppe PE 100-el 28 068...

Art.-Nr.	€/Stück
0110 17	87,15
0125 17	129,60
0160 17	250,85

Rabattgruppe 54

## Bögen 90° / Bend 90°

formgespritzt, aus PE 100-el,  
 $r = d$

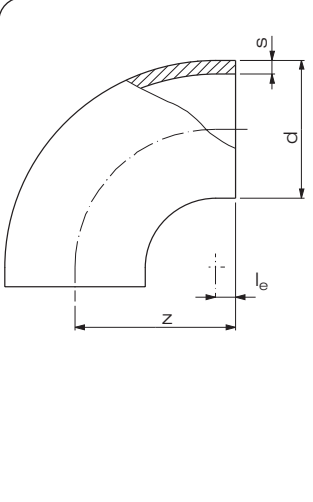
SDR 11					
	d	s	z	l <sub>e</sub>	VE <sup>1)</sup>
	180	16,4	200	20	5
	200	18,2	220	20	6
	225	20,5	243	18	5
	250	22,7	290	25	3
	315	28,6	340	40	1

1) VE = Verpackungseinheit im Karton

Artikelgruppe PE 100-el 28 001...

Art.-Nr.	€/Stück
0180 11	225,55
0200 11	305,50
0225 11	420,30
0250 11	699,30
0315 11	1.128,35

Rabattgruppe 54

## Bögen 90° / Bend 90°

formgespritzt, aus PE 100-el,  
r = d

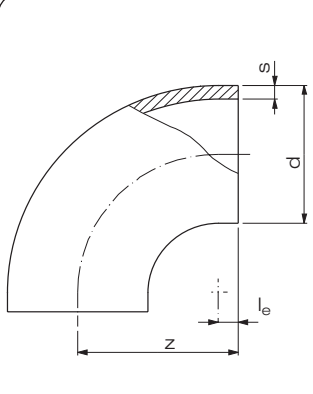
SDR 17	d	s	z	l <sub>e</sub>	VE <sup>1)</sup>
	180	10,7	200	20	5
	200	11,9	220	20	6
	225	13,4	245	20	5
	250	14,8	285	20	3
	315	18,7	335	35	1

1) VE = Verpackungseinheit im Karton

Artikelgruppe PE 100-el 28 001...

Art.-Nr.	€/Stück
0180 17	184,60
0200 17	229,20
0225 17	309,75
0250 17	475,30
0315 17	856,15

Rabattgruppe  
54

## T-Stücke / Tee

verstärkt,  
formgespritzt, aus PE 100-el,

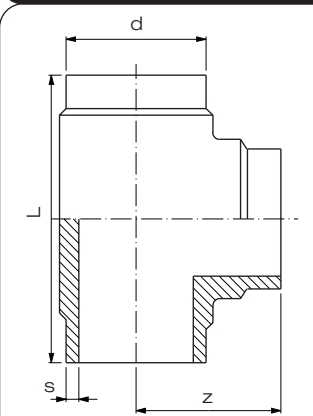
SDR 11	d	s	L	z	VE <sup>1)</sup>
	32	2,9	90	45,0	150
	40	3,7	100	50,0	50
	50	4,6	120	60,0	50
	63	5,8	144	72,0	30
	75	6,8	152	75,0	20
	90	8,2	213	105,0	8
	110	10,0	253	122,0	13
	125	11,4	280	140,0	8
	160	14,6	340	170,0	4
	180	16,4	365	182,5	3
	200	18,2	400	200,0	4
	225	20,5	440	220,0	3
	250	22,7	470	235,0	3
	315	28,6	540	270,0	1

1) VE = Verpackungseinheit im Karton

Artikelgruppe PE 100-el 28 006...

Art.-Nr.	€/Stück
0032 11	8,30
0040 11	12,55
0050 11	16,95
0063 11	26,30
0075 11	52,95
0090 11	79,10
0110 11	116,20
0125 11	159,95
0160 11	340,80
0180 11	437,90
0200 11	594,95
0225 11	746,30
0250 11	946,85
0315 11	1.818,75

Rabattgruppe  
54

## T-Stücke / Tee

verstärkt,  
formgespritzt, aus PE 100-el,

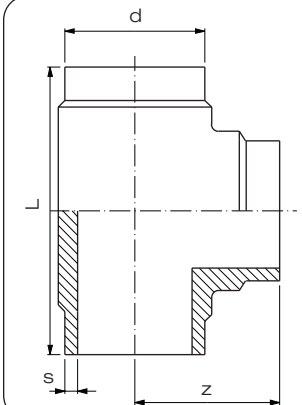
SDR 17	d	s	L	z	VE <sup>1)</sup>
	110	6,6	249	121,0	13
	125	7,4	270	135,0	8
	160	9,5	340	170,0	4
	180	10,7	365	182,5	4
	200	11,9	400	200,0	4
	225	13,4	440	220,0	3
	250	14,8	470	235,0	3
	315	18,7	550	275,0	1

1) VE = Verpackungseinheit im Karton

Artikelgruppe **PE 100-el** 28 006...

Art.-Nr.	€/Stück
0110 17	98,80
0125 17	137,30
0160 17	303,80
0180 17	373,20
0200 17	487,95
0225 17	598,15
0250 17	793,50
0315 17	1.193,30

Rabattgruppe  
54

## Vorschweißbunde / Stub flange

formgespritzt, aus PE 100-el,

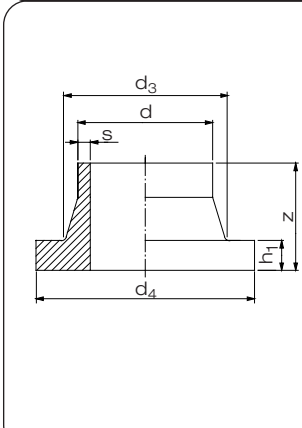
SDR 11	d	s	z	h <sub>1</sub>	d <sub>3</sub>	d <sub>4</sub>	VE <sup>1)</sup>
	32	2,9	50	10	40	68	40
	40	3,7	50	11	50	78	50
	50	4,6	50	12	61	88	80
	63	5,8	50	14	75	102	60
	75	6,8	50	16	89	122	40
	90	8,2	80	17	105	138	20
	110	10,0	80	18	125	158	40
	125	11,4	80	25	132	158	30
	160	14,6	92	25	175	212	18
	180	16,4	93	30	183	212	18
	200	18,2	115	32	232	268	8
	225	20,5	113	32	235	268	7
	250	22,7	132	35	285	320	5
	315	28,6	136	35	335	370	4

1) VE = Verpackungseinheit im Karton

Artikelgruppe **PE 100-el** 28 012...

Art.-Nr.	€/Stück
0032 11	8,45
0040 11	9,75
0050 11	12,30
0063 11	15,45
0075 11	18,20
0090 11	26,10
0110 11	35,20
0125 11	40,45
0160 11	78,45
0180 11	92,75
0200 11	160,00
0225 11	155,70
0250 11	245,80
0315 11	349,75

Rabattgruppe  
54

## Vorschweißbunde / Stub flange

formgespritzt, aus PE 100-el,

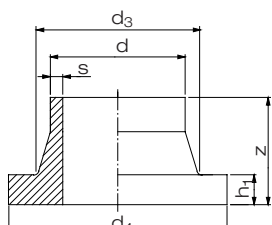
SDR 17	d	s	z	h <sub>1</sub>	d <sub>3</sub>	d <sub>4</sub>	VE <sup>1)</sup>
	110	6,6	80	18	125	158	40
	125	7,4	84	18	132	158	30
	160	9,5	92	18	175	212	20
	180	10,7	92	20	183	212	18
	200	11,9	110	24	232	268	9
	225	13,4	113	24	235	268	7
	250	14,8	132	25	285	320	5
	315	18,7	136	25	335	370	4

1) VE = Verpackungseinheit im Karton

Artikelgruppe PE 100-el 28 012...

Art.-Nr.	€/Stück
0110 17	30,45
0125 17	37,45
0160 17	58,15
0180 17	78,45
0200 17	117,05
0225 17	118,65
0250 17	206,70
0315 17	268,65

Rabattgruppe  
54

## Vorschweißbunde / Stub flange

formgespritzt, aus PE 100-el,

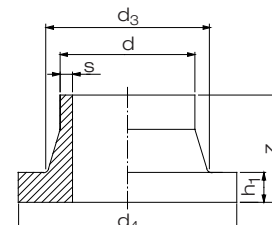
SDR 33	d	s	z	h <sub>1</sub>	d <sub>3</sub>	d <sub>4</sub>	VE <sup>1)</sup>
	110	3,4	80	18	125	158	40
	125	3,9	80	18	132	158	30
	160	4,9	80	18	175	212	20
	180	5,5	92	18	183	212	18
	200	6,2	113	18	232	268	9
	225	6,9	113	18	235	268	7
	250	7,7	132	20	285	320	5
	315	9,7	136	20	335	370	4
	355	10,9	150	23	373	430	7
	400	12,3	155	26	427	482	8

1) VE = Verpackungseinheit im Karton

Artikelgruppe PE 100-el 28 012...

Art.-Nr.	€/Stück
0110 33	30,45
0125 33	37,45
0160 33	53,65
0180 33	78,30
0200 33	94,10
0225 33	105,85
0250 33	149,30
0315 33	192,85
0355 33	329,50
0400 33	684,45

Rabattgruppe  
54

## Losflansche Typ „VB“ / Backing ring type „VB“ nach DIN EN ISO 15494 für Vorschweißbunde

PPs-el in Schwarz, glasfaserverstärkt,  
mit Stahleinlage, Lochbild nach DIN EN 1092-1, bis d 180 = PN 10/ PN 16;  
ab d 200 = PN 10

Artikelgruppe

PPs-el

19 014...

PN 10 / PN 16	d	DN	D	d <sub>6</sub>	Lochbild		b	VE <sup>1)</sup>	
					k	d <sub>2</sub>			
bis d 315 bis PN 16 einsetzbar	32	25	115	42	85	4 x 14	16	30	
	40	32	140	51	100	4 x 18	18	30	
	50	40	150	62	110	4 x 18	18	16	
	63	50	165	78	125	4 x 18	18	16	
	75	65	187	92	145	4 x 18	18	15	
	90	80	202	108	160	8 x 18	20	10	
	110/125	100	220	133	180	8 x 18	20	11	
	160/180	150	286	190	240	8 x 22	23	10	
	200	200	340	235	295	8 x 22	24	5	
	225	200	340	238	295	8 x 22	24	5	
	250	250	409	288	350	12 x 22	30	lose	
	315	300	463	338	400	12 x 22	34	lose	

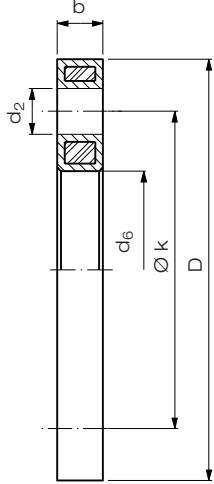

1) VE = Verpackungseinheit im Karton

Art.-Nr.	€/Stück
0032 11	31,30
0040 11	39,50
0050 11	46,35
0063 11	53,40
0075 11	59,25
0090 11	70,50
0110 11	112,45
0160 11	163,60
0200 11	210,35
0225 11	210,35
0250 11	335,55
0315 11	421,80

Rabattgruppe  
52

## Reduktionen / Reducer concentric

zentrisch,  
formgespritzt, stufenweise abgesetzt, aus PE 100-el,

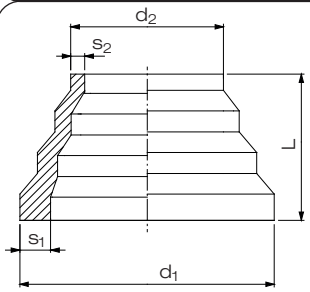
SDR 11	$d_1$	$d_2$	$s_1$	$s_2$	L	VE <sup>1)</sup>
	63	16	5,8	1,8	55	200
	110	63	10,0	5,8	63	30
	160	110	14,6	10,0	84	8
	225	160	20,5	14,6	90	15
	315	225	28,6	20,5	130	5

1) VE = Verpackungseinheit im Karton

Artikelgruppe PE 100-el 28 007...

Art.-Nr.	€/Stück
6316 11	15,00
1163 11	31,70
1611 11	119,30
2216 11	323,35
3122 11	357,60

Rabattgruppe  
54

## Reduktionen / Reducer concentric

zentrisch,  
formgespritzt, stufenweise abgesetzt, aus PE 100-el,

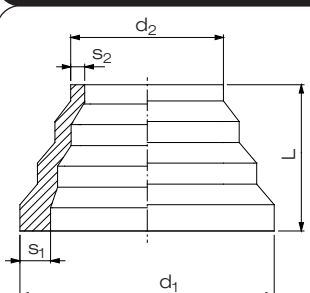
SDR 17	$d_1$	$d_2$	$s_1$	$s_2$	L	VE <sup>1)</sup>
	160	110	9,5	6,6	83	10
	225	160	13,4	9,5	90	18
	315	225	18,7	13,4	130	6

1) VE = Verpackungseinheit im Karton

Artikelgruppe PE 100-el 28 007...

Art.-Nr.	€/Stück
1611 17	111,30
2216 17	293,65
3122 17	332,90

Rabattgruppe  
54

## SureAMID / SureAMID

aus PA 12, gelb, nach DIN EN ISO 16486-2,  
optimal geeignet für alternative Verlegung,  
in Standardlängen von 6 m

SDR 11	d	s	d <sub>i</sub>
	110	10,0	90,0
	160	14,6	130,8

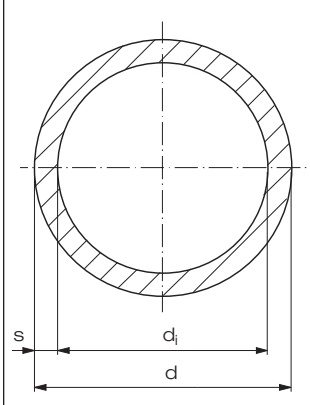

Artikelgruppe **PA 12** 7P 709...

Art.-Nr.	€/m
0110 11	a. A.
0160 11	a. A.

Rabattgruppe  
objektbezogen

## E-Muffen / E-coupler

aus PA 12, gelb, nach DIN EN ISO 16486-3, optimal geeignet für alter-  
native Verlegung, mit eingebetteten Heizwendeln zum schonenden  
Energieeintrag und zum besseren Ausgleich von Rohrovalitäten.

SDR 11	d	D	L
	110	136	149
	160	197	180

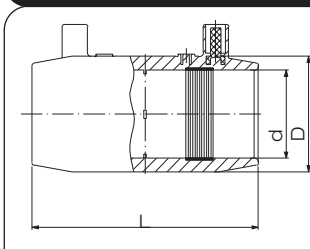



Artikelgruppe **PA 12** 7P 173...

Art.-Nr.	€/Stück
0110 11	a. A.
0160 11	a. A.

Rabattgruppe  
objektbezogen

## Winkel 45° / Elbow 45°

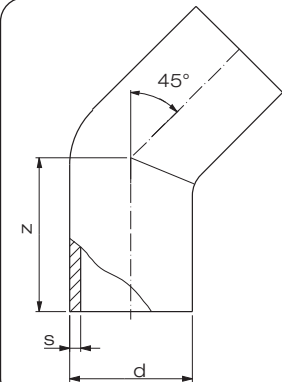
aus PA 12, gelb, nach DIN EN ISO 16486-3,  
mit langen Schweißenden

SDR 11	d	s	z
	110	5,3	68
	160	7,7	103



1) VE = Verpackungseinheit im Karton

Artikelgruppe **PA 12** 7P 060...

Art.-Nr.	€/Stück
0110 11	a. A.
0160 11	a. A.

Rabattgruppe  
objektbezogen

## Vorschweißbunde / Stub flange

aus PA 12, gelb, nach DIN EN ISO 16486-3,  
mit langen Schweißenden

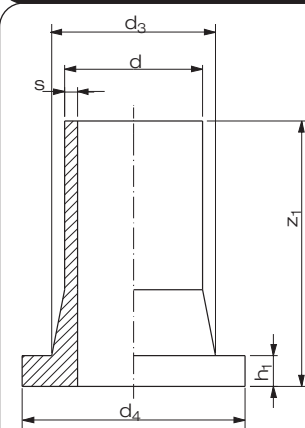
SDR 11	d	s	h <sub>1</sub>	z <sub>1</sub>	d <sub>3</sub>	d <sub>4</sub>
	110	10,0	18	159	125	158
	160	14,6	25	200	175	212



Artikelgruppe **PA 12** 7P 062...

Art.-Nr.	€/Stück
0110 11	a. A.
0160 11	a. A.

Rabattgruppe  
objektbezogen

## Losflansche Typ "VB" / Backing ring type "VB" nach DIN EN ISO 15494 für Vorschweißbunde

PP Schwarz oder Grau in PN 10, glasfaserverstärkt, mit Stahleinlage, Lochbild nach DIN EN 1092-1; Sonderflansche befinden sich im Kapitel "Flansche und Sonderteile"

Artikelgruppe **PP-G Schwarz** 14 014...

Lochbild PN 10/16	Lochbild								
	d	DN	D	d <sub>6</sub>	k	d <sub>2</sub>	b	VE <sup>1)</sup>	VE <sup>2)</sup>
bis 16 bar einsetzbar	110	100	220	128	180	8 x 18	20	11	264
	160	150	286	178	240	8 x 22	24	7	168

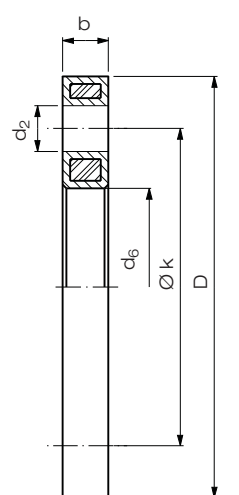

Auf Anfrage als Lüftungsflansche ohne Stahleinlage lieferbar.

- 1) VE = Verpackungseinheit im Karton
- 2) VE = Verpackungseinheit pro Palette

Art.-Nr.	€/Stück
0110 11	83,15
0160 11	136,45

Rabattgruppe  
PP-G 28

## Reduktionen / Reducer concentric

aus PA 12, gelb, nach DIN EN ISO 16486-3,  
mit langen Schweißenden, zentrisch

Artikelgruppe **PA 12** 7P067...

SDR 11	d <sub>1</sub>	d <sub>2</sub>	s <sub>1</sub>	s <sub>2</sub>	L
	160	110	14,6	10,0	225

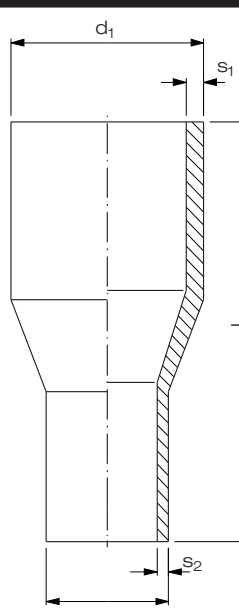

Art.-Nr.	€/Stück
1611 11	a. A.

Rabattgruppe  
objektbezogen

## Endkappen / End cap

aus PA 12, gelb, nach DIN EN ISO 16486-3,  
mit langen Schweißenden

Artikelgruppe

PA 12

7P 064...

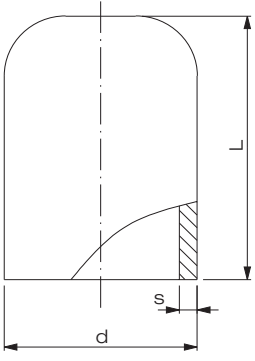
SDR 11	d	s	L
	110	10,0	133
	160	14,6	168



Art.-Nr.

€/Stück

0110 11

a. A.

0160 11

a. A.

Rabattgruppe  
objektbezogen