

Butterfly valve type 57 L



Body material	PDCPD	
Disc material	PP	PVDF
Sealing material (optionally)	• EPDM	• FKM-F
Working temperature ¹⁾	-20 °C up to 90 °C ²⁾	-20 °C up to 100 °C ²⁾
Nominal size	DN 80 up to DN 200 (Gear with handwheel up to DN 250)	
Connection with pipe	Lug type valve with directional pressurization in case of maintenance and connection dimensions acc. to DIN EN 1092-1 - PN 10 ³⁾	
Length	Company standard	
Actuator	Lockable lever with 19 positions, or infinitely variable gear, optionally pneumatic or electric actuator	
Accessories	Limit switches, shaft extension	

1) Designed for 10 years of use with a neutral medium (water)

3) also acc. ANSI or JIS available

2) Working temperatures for sealing materials:

EPDM: -20 up to 90 °C

FKM / FKM-F: -5 up to 120 °C

Example for an invitation to tender text:

Butterfly valve type 57 L, DN 150, PN 10, PP / EPDM, lug type valve with connection dimensions acc. to DIN EN 1092-1 - PN 10, gear with handwheel and optical position indicator, directional pressurization in case of maintenance

Document: FRANK_DB_L2_Absperrklappe Typ 57a L_01-2024_EN

Butterfly valve type 57 L

DN 80 up to DN 200

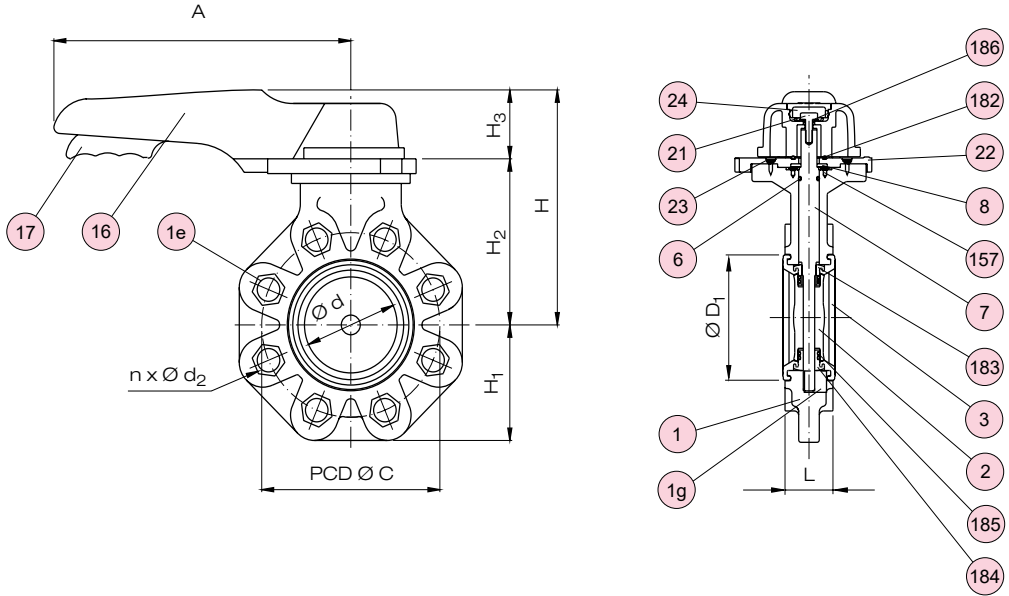

DN 80 up to DN 250

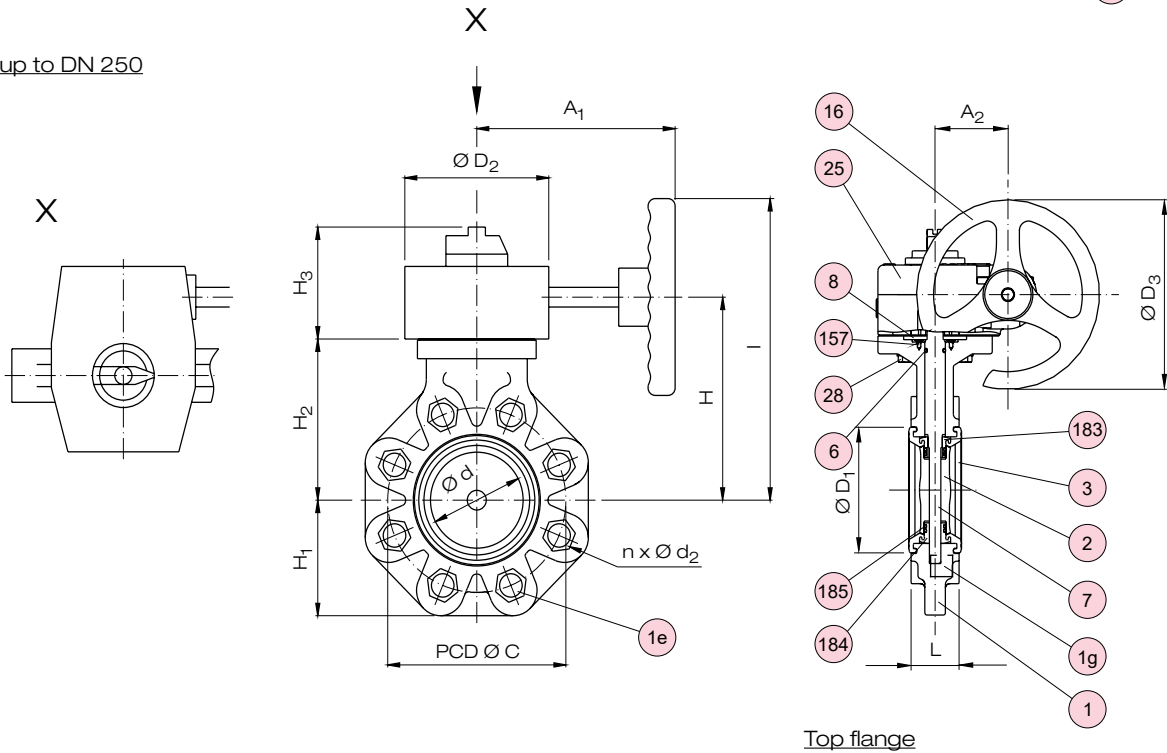

Top flange

Profile 1 - 1:

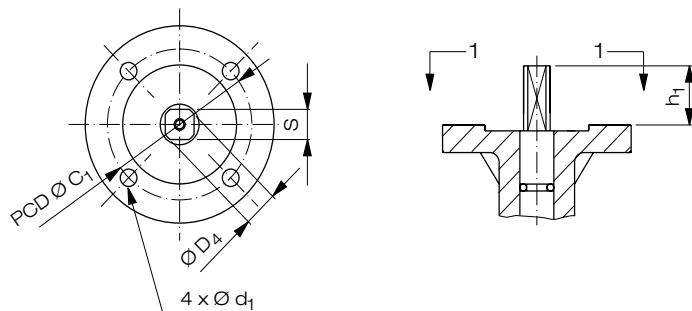

Top flange dimensions in [mm] for fixation and actuator mounting (DIN EN ISO 5211)

DN	type	C ₁	h ₁	d ₁	D ₄	S
80	F07	70	30	9	17	14
100	F07	70	30	9	17	14
125	F10	102	35	11	21	17
150	F10	102	35	11	21	17
200	F10	102	35	11	24	19
250	F10	102	35	11	27	22

Butterfly valve type 57 L

No.	Description	Number	Material
1	Body	1	PDCPD
1e	Lug-insert	8 ¹⁾	A2 - 1.4301 (SUS 304)
1g ²⁾	Collar bushing	1	A2 - 1.4301 (SUS 304)
	Threaded plate	2	1.4308 (SCS 13)
2	Disc ³⁾	1	PVC, PP, PVDF
3	Seat ³⁾	1	EPDM, FKM, FKM-F
6	O-ring (C) ⁴⁾	1	EPDM, FKM, FKM-F
7	Stem	1	1.4000 (SUS 403) ³⁾
8	Stem retainer	1	PP
16	Lever / handwheel ⁴⁾	1	PP
17	Hand lever	1	PPG
18	Pin	1	PPG
19	Spring	1	A2 - 1.4301 (SUS 304)

- *) Wearing parts
 1) at DN 250: 12 pc
 2) Collar Bushing from DN 125
 Threaded plate from DN 200

No.	Description	Number	Material
21	Hexagonal bolt (B)	1	A2 - 1.4301 (SUS 304)
22	Locking plate	1	PPG
23	Screw (B)	4	A2 - 1.4301 (SUS 304)
24	Cap (A)	1	PP
25	Gear box	1	PDCPD
28	Hexagonal bolt	4	A2 - 1.4301 (SUS 304)
157	Screw	4	A2 - 1.4301 (SUS 304)
182	O-ring ⁵⁾	1	EPDM
183	Seat bush (A) ⁵⁾	1	PVC-U, PP, PVDF
184	Seat bush (B) ⁵⁾	1	PVC-U, PP, PVDF
185	O-ring ⁵⁾	4	EPDM, CSM, FKM, FKM-F
186	Washer / Rubber	1	A2 - 1.4301 (SUS 304) with EPDM

- 3) other material on request
 4) Lever type with inserted stainless steel stem connector: A4 - 1.4404 (SUS 316 L)
 5) only for gear box type

Dimensions and weights

Dimensions in mm																				
DN	d	C	D ₁	D ₂	L	H ₁	n x d ₂ ⁶⁾	Hand lever				Gear with handwheel				Weight in kg / pc ⁸⁾				
								A	H	H ₂	H ₃	A ₁	A ₂	I	H	H ₂	H ₃	D ₃	Disc-PP	Disc-PVDF
80	77	160	105	122	46	94	8 x M16x40	250	191	135	56	167	64	245	165	130	92	160	2,5 / 4,5	2,6 / 4,6
100	102	180	134	122	56	105	8 x M16x40	250	206	150	56	167	64	260	180	145	92	160	3,0 / 5,0	3,2 / 5,2
125	129	210	169	122	66	124	8 x M16x50	320	237	168	69	167	64	275	195	160	92	160	5,6 / 7,1	5,9 / 7,4
150	150	240	190	122	71	138	8 x M20x50	320	252	183	69	167	64	290	210	175	92	160	7,1 / 8,6	7,6 / 9,1
200	195	295	242	122	87	173	M20 ⁷⁾	400	283	214	69	167	64	321	241	206	92	160	11,6 / 13,0	12,5 / 13,9
250	250	350	302	188	112	208	12 x M20x70	-	-	-	-	242	99	426	283	241	108	300	- / 22,7	- / 24,3

- 6) Lug-Insert (No. 1e)
 7) 4 x M20x50 und 4 x M20x60
 8) Lever type / gear type

Flow rate characteristic value⁹⁾ k_{VS} in m³/h

DN	Opening degree			
	25 %	50 %	75 %	100 %
80	5,1	51	143	256
100	8	80	225	402
125	14	142	397	709
150	19	188	526	940
200	43	427	1197	2137
250	66	660	1848	3300

- 9) Definition k_{VS} -value see chapter T2 / technical information

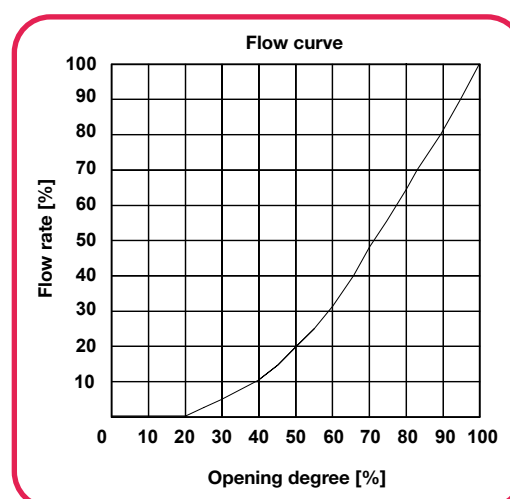

Butterfly valve type 57 L

Tightening torque in Nm for flange bolts

DN	Torque
80, 100	30
125, 150	40
200, 250	55

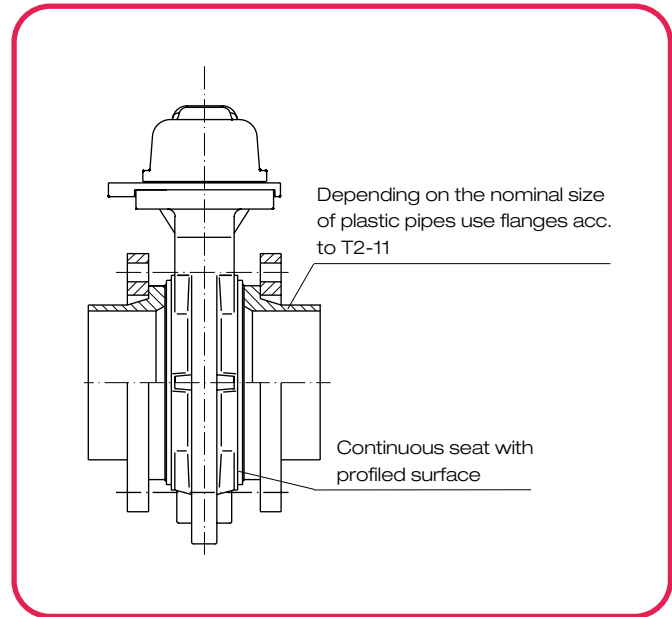

Working pressure¹⁾ p_B in bar
- Operation as wafer type -

Disc-material	Temp. in °C	DN
		80 - 250
PP	-20 up to 50	10
	up to 60	6
	up to 70	4
	up to 90	2
PVDF	-20 up to 60	10
	up to 70	8
	up to 100	5

1) Definition see chapter T2 / Technical information



Note:

The partly removable lug inserts need a defined mounting direction for maintenance. This is marked with arrows on the body (usually this is the flow direction, too).

By removing the lug inserts the butterfly valve can be used as wafer style valve (DN 80-150).

Please consider our operation- and maintenance guide: FRANK_BA_L2_Absperrklappe Typ 57L_08-2010_EN

Operating torque²⁾ in Nm

DN					
80	100	125	150	200	250
30	40	65	69	215	350

2) Referring to maximum working pressure

Vacuum resistance³⁾ in bar

DN					
80	100	125	150	200	250
1,0	1,0	1,0	0,91	0,91	0,91

3) Referring to maximum working temperature

Butterfly valve type 57 L

Pressure loss diagram

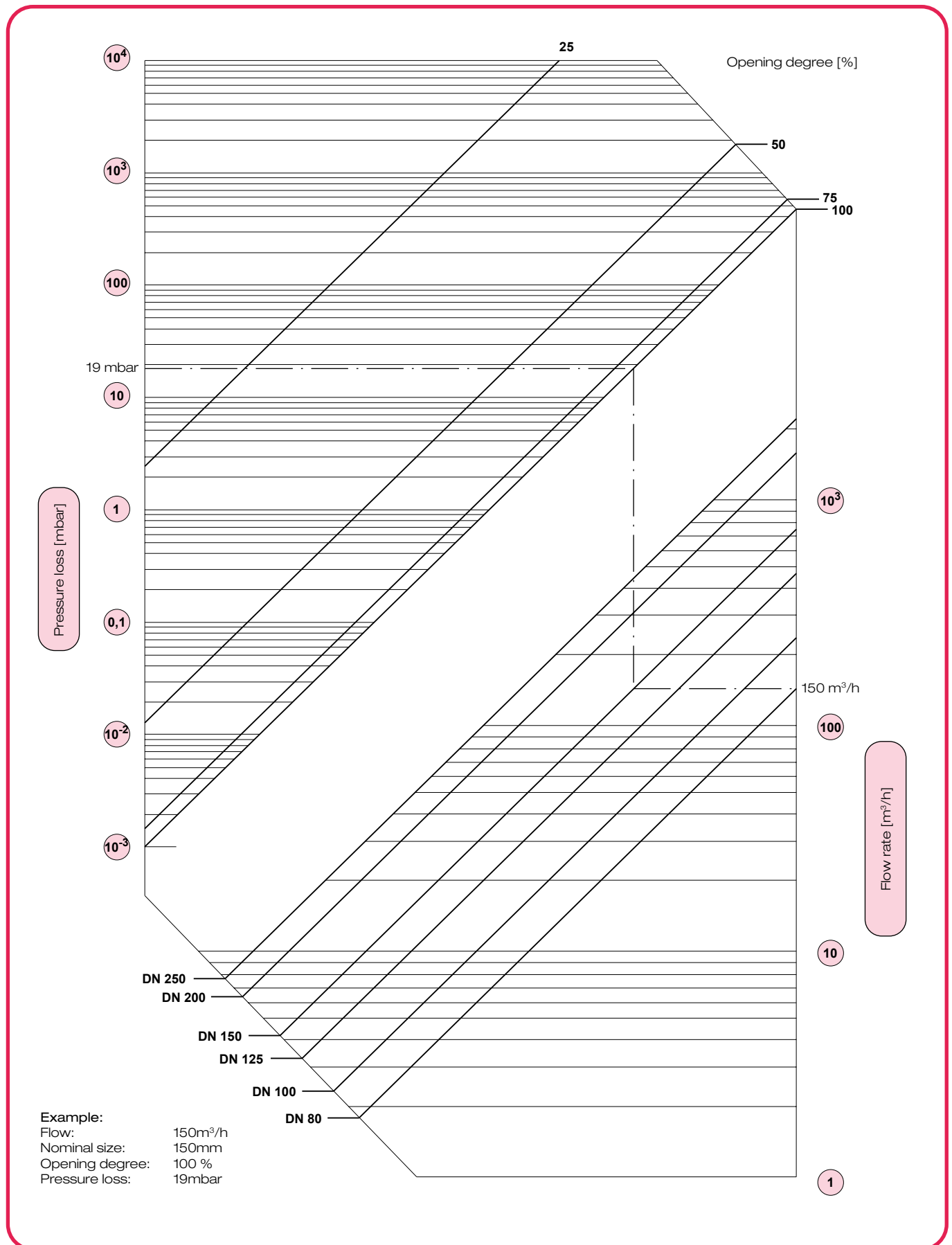

Butterfly valve type 57 L

Maintenance and installation

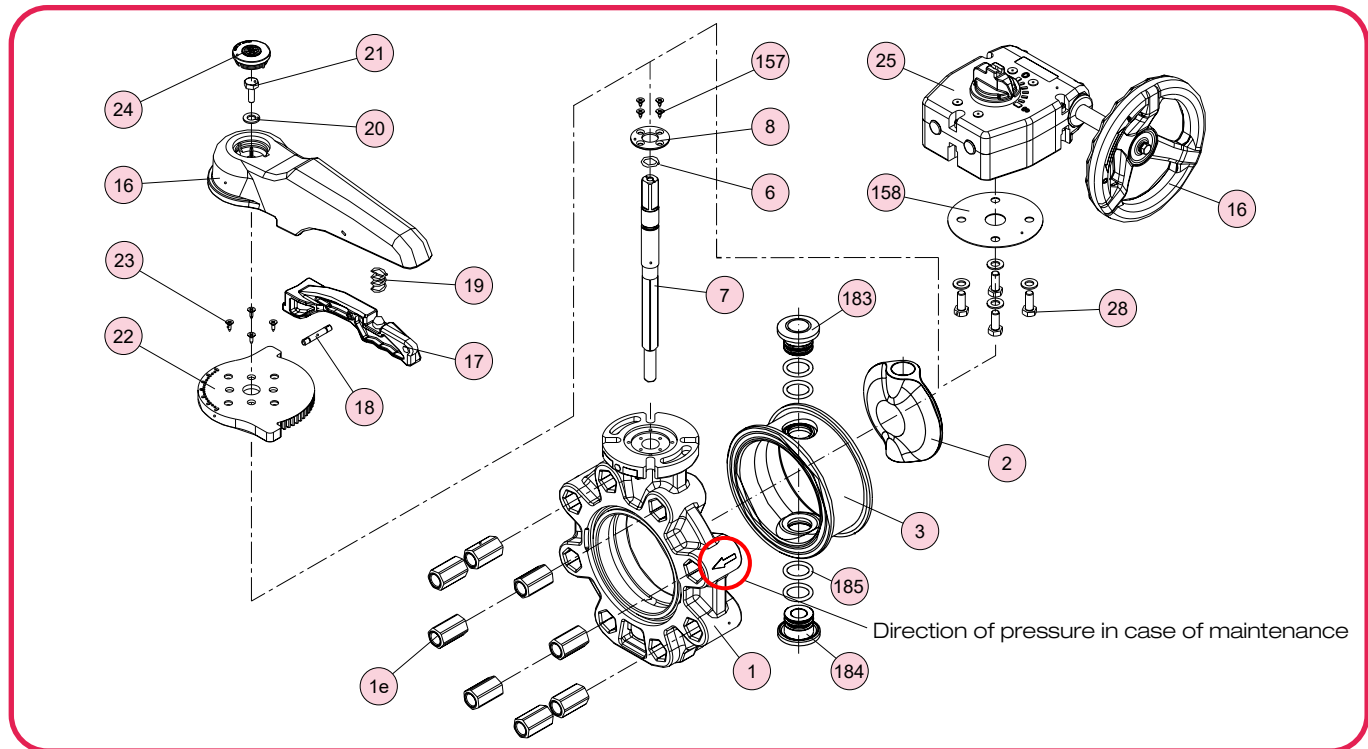

Lever or gear version

Disassembly of the valve

Caution: Never dismantle the valve when the pipe is under pressure.

- Drain fluid completely from the pipeline.
- Leave the valve slightly opened.
- Loosen the connecting bolts and nuts.
- Remove the valve from the pipeline.

Lever version:

- To take off lever 16, firstly take off cap 24 by using a screw driver and release bolt 21 by using a socket wrench, then pull up the lever 16 while holding handle lever 17.
- Remove bolts 23 and remove locking plate 22.

Gear version:

- Remove bolts 28 and remove gear box 25.

Lever and Gear version:

- Remove bolts 157 and remove stem retainer 8.
- Pull the stem 7 out of the body 1.
- Push disc 2 with seat 3 out of the body 1.
For this shift 90° to rotating axis the lever between body and seat (disc open). Via the lever, press seat with disc out of the body.
- Remove seat bush 183 and 184.

Assembly of the valve

- The valve assembly is to be performed in reverse order to the disassembly.
- Before the assembly all parts have to be checked for damages.
- All parts have to be clean.

- For installation of seat 3 with disc 2, it is absolutely necessary to ensure that:
 - the seat bush 183 and 184 are correctly assembled.
 - the seat has to be put in correct position (seat bush 183 with the bigger hole must be directed to the top flange).
- For installing the disc 2, press the seat 3 and together install the disc between the seat bush 183 and 184.
- The stem is to be mounted in a way that its top mark complies with the disc position.
- After assembly carry out a pressure test acc. to DIN EN 12266-1.

Notes for correct installation

- Because of the full cover seat additional flange gaskets are not necessary.
- Install the valve without invoking material stress, therefore be aware of flange face parallelism, axial misalignment and valve length.
- For use with media containing solids or sediments the valve should be installed with the stem in horizontal position and the disc opening in flow direction.
- Depending on the size chamfered stub flanges according T2-11 have to be used.
- If you use the type 57L as lug style valve the pressure direction has to be in accordance with the arrows on the body for maintenance.
- If you use the type 57L as end device of a piping system it is recommended to mount an additional blind flange.
- For using butterfly valves DN150 with stub flanges d180 bigger SDR 17 please use chamfered stub flanges.