

## Ball valve type 21 externally controlled, other connections

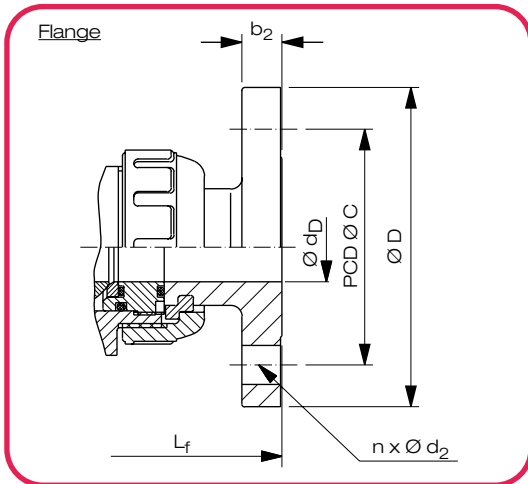

Dimensions in mm							Additional weight in kg / pc.			
DN	K	D	d <sub>D</sub>	b <sub>2</sub>	n x d <sub>2</sub>	L <sub>f</sub>	PVC-U	PVC-C	PP	PVDF
15	65	95	15	12	4 x 14	130	0,2	0,2	0,2	0,3
20	75	105	20	14	4 x 14	150	0,3	0,4	0,2	0,4
25	85	115	25	14	4 x 14	160	0,4	0,4	0,2	0,5
32	100	140	31	16	4 x 18	180	0,6	0,6	0,4	0,8
40	110	150	40	16	4 x 18	200	0,7	0,8	0,5	0,8
50	125	165	51	16	4 x 18	230	0,8	0,9	0,5	1,1
65	145	185	58	18	8 x 18	290	0,9	0,9	0,6	1,2
80	160	200	68,5	21	8 x 18	310	0,8	0,9	0,7	1,3
100	180	220	90	18	8 x 18	350	0,6	0,7	0,6	1,3

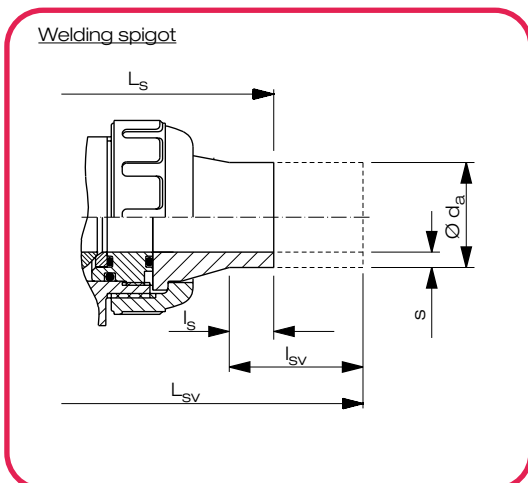

Dimensions in mm							
DN	da	s <sup>3)</sup> SDR 17	s <sup>3)</sup> SDR 11	l <sub>sv</sub> <sup>2)</sup>	l <sub>s</sub> <sup>1)</sup>	L <sub>sv</sub> <sup>2)</sup>	L <sub>s</sub> <sup>1)</sup>
15	20	-	1,9	64	30	239	167
20	25	-	2,3	61	25	244	168
25	32	-	2,9	61	25	253	175
32	40	-	3,7	67	24	289	185
40	50	3,0	4,6	69	22	295	199
50	63	3,8	5,8	78	20	360	212
65	75	4,5	6,8	89	18	384	232
80	90	5,4	8,2	101	40	451	325
100	110	6,6	10,0	115	38	516	352

1) Weld spigot (PE 100, PP-R, PVDF)

2) long weld spigots (PE 100, PP-R) for electric welding

3) PVDF-weld spigot SDR 33 / SDR 21 with differing wall thickness

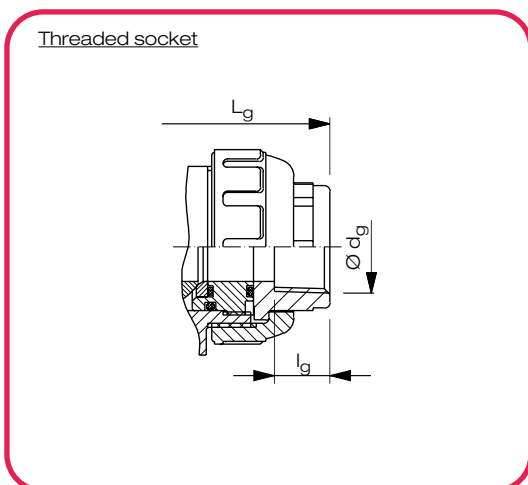

Dimensions in mm			
DN	d <sub>g</sub>	l <sub>g</sub>	L <sub>g</sub>
15	Rp 1/2"	14	96
20	Rp 3/4"	16	120
25	Rp 1"	19	134
32	Rp 1 1/4"	20	150
40	Rp 1 1/2"	25	168
50	Rp 2"	28	196
65	-	-	-
80	-	-	-
100	-	-	-