

Wafer check valve type 34



Body material	PVC-U	PP	PVDF
Sealing material (optionally)	• EPDM • FKM • PTFE		
Working temperature	0 °C up to 50 °C ¹⁾	0 °C up to 80 °C ¹⁾	0 °C up to 100 °C ¹⁾
Nominal size	DN 32 up to DN 500		
Connection with pipe	Wafer type acc. to DIN EN 1092-1 (replaces DIN 2501) - PN 10		
Length	Company standard		
Options	Return spring ²⁾ , flow booster ³⁾		

²⁾ Optional made of V4A or Hastelloy

³⁾ in case of mounting into a plastic piping system depending on size and wall thickness of downstream, a flow booster is necessary

¹⁾ Working temperatures for sealing materials:

EPDM: -20 up to 90 °C

FKM: -20 up to 120 °C

PTFE: -20 up to 250 °C

Example for an invitation to tender text:

Wafer check valve type 34, DN 200, PN 6, PVDF / FKM, wafer type with flange connection acc. to DIN EN 1092-1 - PN 10

Document: FRANK_DB_L5_Zwischenbau-Rückschlagklappe Typ 34_05-2020_EN

Wafer check valve type 34

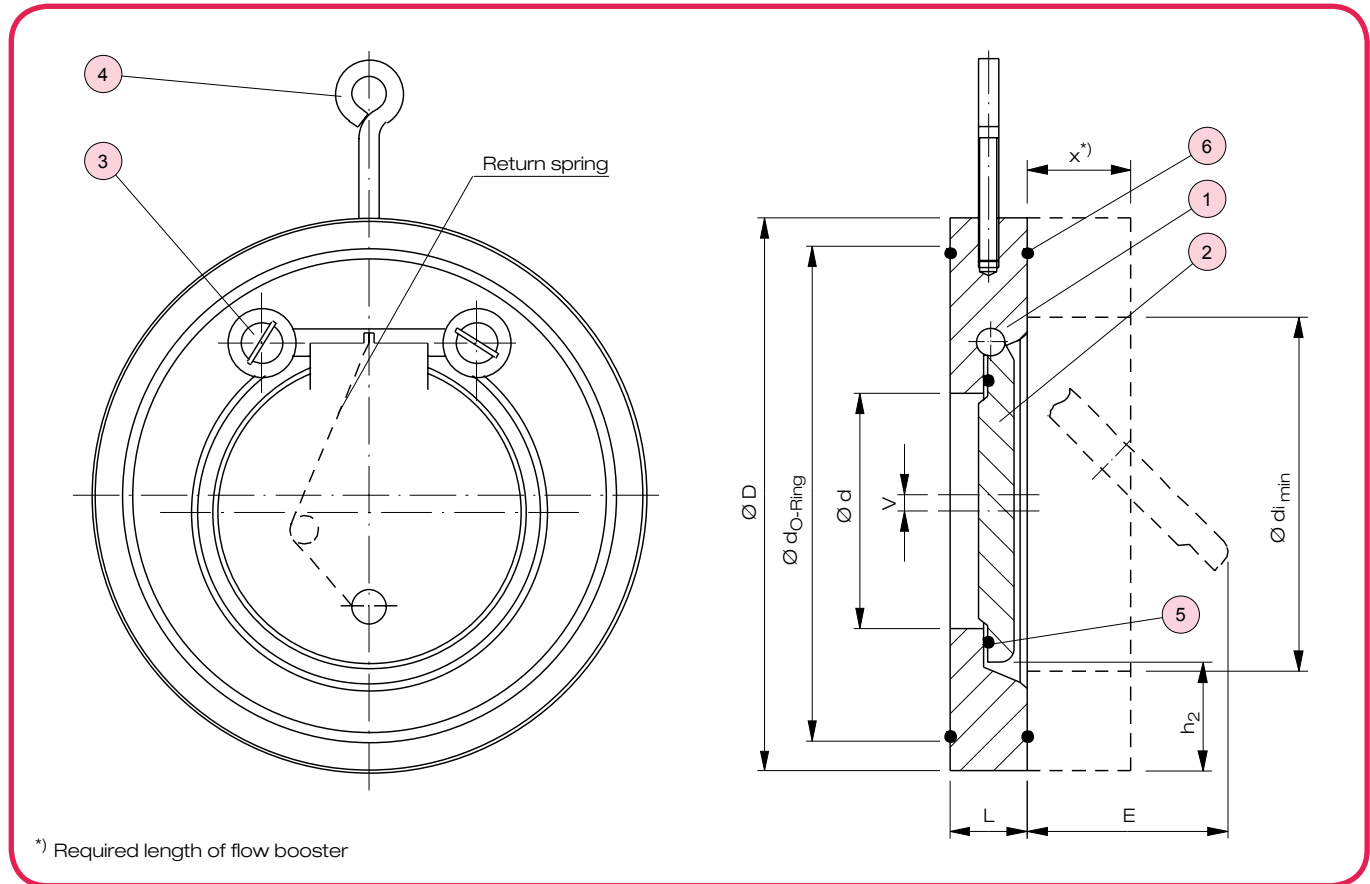

*) Required length of flow booster

No.	Description	Number	Material
1	Body	1	PVC-U, PP, PVDF
2	Disc ^{*)}	1	PVC-U, PP, PVDF
3	Screw ^{*)}	2	PVC, PVDF

No.	Description	Number	Material
4	Ring bolt	1	St 37, zinc coated
5	O-ring ^{*)}	1	EPDM, FKM, PTFE ¹⁾
6	O-ring ^{*)}	2	EPDM, FKM, PTFE ¹⁾

*) Wearing parts
 1) Special version: CSM, NBR on request

Dimensions and weights

DN	Dimensions in mm									Weight in kg / pc.		
	d	d _{O-ring}	D	h ₂	d _{i min}	E	x	L	V	HI-PVC	PP	PVDF
32	18	59	85	25	39	22	20	15	2,0	0,13	0,09	0,17
40	22	72	95	28	47	25	20	16	1,5	0,16	0,10	0,21
50	32	86	109	29	59	37	25	18	3,2	0,25	0,17	0,33
65	40	105	129	31	75	50	40 ⁴⁾	20	3,5	0,32	0,22	0,42
80	54	119	144	32	89 ²⁾	61	40 ⁴⁾	20	3,5	0,39	0,26	0,51
100	70	146	164	31	110 ³⁾	77	50 ⁵⁾	23	6,0	0,55	0,37	0,71
125	92	173	195	35	125	94	50	23	7,5	0,75	0,50	0,97
150	105	197	220	40	152	100	50 ⁵⁾	26	8,0	1,10	0,74	1,42
200	154	255	275	38	200	152	70	34	11,0	2,10	1,40	2,71
250	192	312	330	41	256	180	100	40	12,5	3,50	2,40	4,52
300	227	363	380	41	308	215	165	45	20,0	5,30	3,52	6,90
350	266	416	440	54	355	245	200	49	16,0	7,50	5,10	9,70
400	310	467	491	55	391	285	6 ⁶⁾	65	19,0	11,00	7,30	14,30
500	400	550	596	58	490	385	6 ⁶⁾	87	24,0	21,30	14,00	27,60

²⁾ PVDF = 85 ³⁾ PVDF = 106 ⁴⁾ PVDF = 30 ⁵⁾ PVDF = 40 ⁶⁾ on request

Wafer check valve type 34

Minimum required shut and opening pressures in bar (for H₂O, 20 °C)

DN	Without spring		With spring			
	Vertical installation		Vertical installation		Horizontal installation	
	Open	Close	Open	Close	Open	Close
32	0,01	0,1	0,02	0,05	0,023	0,1
40	0,01	0,1	0,02	0,05	0,015	0,1
50	0,01	0,1	0,02	0,05	0,015	0,1
65	0,01	0,1	0,02	0,05	0,015	0,1
80	0,01	0,1	0,02	0,05	0,015	0,1
100	0,01	0,2	0,02	0,1	0,015	0,1
125	0,01	0,2	0,02	0,1	0,015	0,2
150	0,01	0,2	0,02	0,1	0,015	0,2
200	0,02	0,2	0,03	0,1	0,015	0,2
250	0,02	0,3	0,03	0,2	0,025	0,3
300	0,02	0,3	0,03	0,2	0,025	0,3
350	0,03	0,45	0,04	0,3	0,035	0,4
400	0,03	0,45	0,04	0,3	0,035	0,4
500	0,03	0,45	0,04	0,3	0,035	0,4

Flow rate characteristic value¹⁾ k_{VS} in m³/h

DN	32	40	50	65	80	100	125	150	200	250	300	350	400	500
k_{VS} [m ³ /h]	15	27	58	88	110	213	497	674	906	1638	1932	3216	4050	4848

¹⁾ Definition k_{VS} -value see chapter T2 / technical information

Working pressure²⁾ p_B in bar

Body-material	T_B in °C	DN		
		32 - 250	300	350 - 500
PVC-U	0 up to 20	5	5	3
	30	3	3	1,5
	50	1	1	0,5
PP	0 up to 20	6	6	4
	40	4	4	2,5
	60	2	2	1
	80	0,9	0,9	0,5
PVDF	0 up to 20	8	5	5
	50	6	5	3
	80	3	3	1
	100	1	1	0,5

²⁾ Definition see chapter T2 / technical information

Recommended maximum flow rate in l/min³⁾ at pump start and shut down

DN	32	40	50	65	80	100	125	150	200	250	300	350	400	500
Q_{max}	45	81	190	265	416	757	1100	1211	1514	2271	2839	4660	5720	6790

³⁾ Maximum acceptable values to protect the disc from being damaged by pump blows.

Wafer check valve type 34

Pressure loss diagram

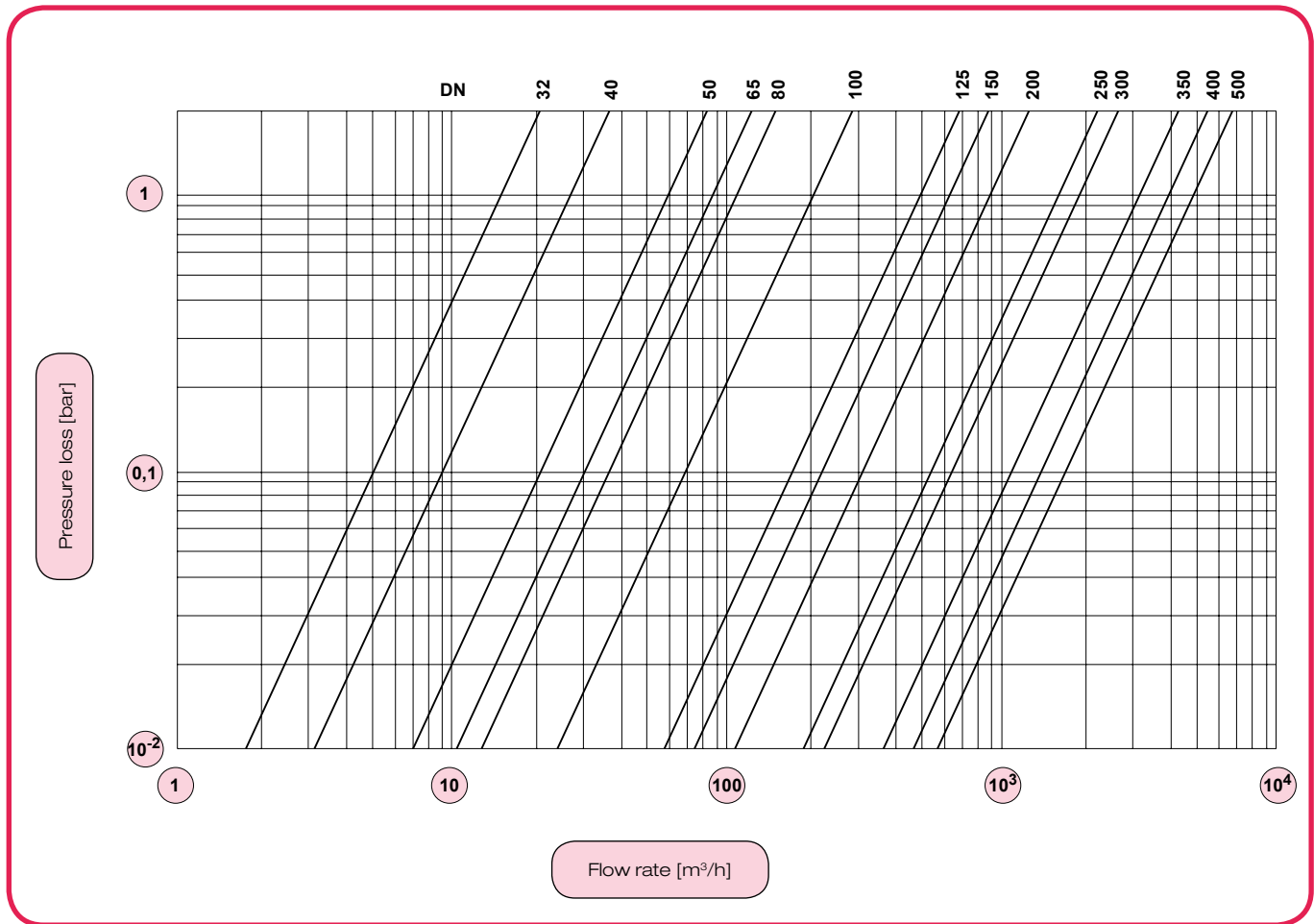

Notes for correct installation

- Attention: Mounting the wafer check valve between flanges acc. to DIN EN 1092-1 - PN 10 please make sure $\varnothing d_{i \min}$ at a length x on down stream side for correct opening of the disc.
- See as follows our flow boosters for mounting on down stream side in connection with plastic pipes, especially PE and PP.
- For pulsating media and horizontal installation principally use wafer check valve with return spring.

- Do not install wafer check valves directly on pump flanges or following elbows.
- For the installation of a wafer check valve make sure a minimum upstream and downstream of 5 times inside diameter to avoid negative turbulences.

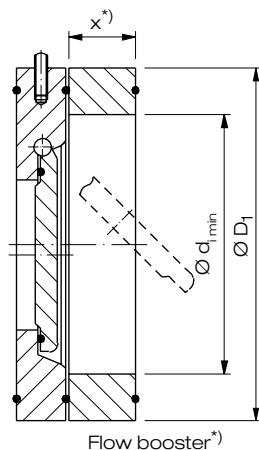

DN	Dimensions in mm			Weight in kg / pc.	
	$d_{i \min}$	D_1	x	PP	PVDF
32	39	85	20	0,13	0,17
40	47	95	20	0,15	0,20
50	59	109	25	0,23	0,31
65	75	129	40 ³⁾	0,46	0,62
80	89 ¹⁾	144	40 ³⁾	0,48	0,65
100	110 ²⁾	164	50 ⁴⁾	0,76	1,04
125	125	195	50	0,97	1,31
150	152	220	50 ⁴⁾	1,03	1,40
200	200	275	70	2,20	2,98
250	256	330	100	4,60	6,24
300	308	380	165	5,96	8,09
350	355	440	200		
400	391	491	200		
500	496	596	280		

< on request >

1) PVDF = 85 2) PVDF = 106 3) PVDF = 30 4) PVDF = 40

*) Attention: lengths of flange bolts vary according to DN!